

LEGEND



ADVENTURERS HANDBOOK



ADVENTURER'S HANDBOOK

CONTENTS

Introduction.....	3
Treihadwyl - Level 1.....	5
Treihadwyl - Level 2.....	7
Fagranc - Level 1.....	9
Fagranc - Level 2.....	11
Dark Tower - Level 1.....	13
Dark Tower - Level 2.....	15
Dark Tower - Level 3.....	17
Dark Tower - Level 4.....	19
Dark Tower - Level 5.....	21
Fagranc - Level 3.....	23
Fagranc - Level 4.....	25
Balenhalm - Level 1.....	27
Moonhenge - Level 1.....	29
Moonhenge - Level 2.....	31
Fagranc - Level 5.....	33
Fagranc - Level 6.....	35
The Unshrine - Level 1.....	37
The Unshrine - Level 2.....	39
Fagranc - Level 7.....	41
Fagranc - Level 8.....	43
The King - Level 1.....	45
The King - Level 2.....	47
The King - Level 3.....	49
Help and Advice.....	50
Level Solutions.....	57
Detailed Room Solutions.....	68
Moonhenge - the mappers nightmare!.....	68
A. Treihadwyl - Level 2 - Room 10.....	70
B. Fagranc - Level 1 - Room 28.....	71
C. Dark Tower - Level 1 - Room 32.....	72
D. Dark Tower - Level 3 - Room 14.....	73
E. Fagranc - Level 3 - Room 17.....	75
F. The Unshrine - Level 1 - Room 26.....	77
G. Fagranc - Level 8 - Room 30.....	78
H. The King - Level 1 - Room 30.....	79
I. The King - Level 2 - Room 2.....	80
J. The King - Level 2 - Room 2.....	82
APPENDIX A - Object Effects.....	84
APPENDIX B - Magic Runes and their cost.....	89
APPENDIX C - Apothecaries.....	90
APPENDIX D - Locations.....	92
APPENDIX E - Rewards.....	93
APPENDIX F - Magic Spells.....	94
APPENDIX G - Bardish Melodies.....	96
APPENDIX H - Reviews.....	98

The "Legend" Adventurer's Handbook (v1.06) – **This edition by Richard Hewison (November 2007)**

Compiled and written by Richard Hewison in association with Tag and Pete James, (without whom the game would never have existed!)

Produced by David 'Pog' Amor

Special hellos go to Sue Medley, John Wilson, Paul Allen and all at Mindscape International.

Design and artwork by Duncan Design

Notes

This new edition of the Legend Adventurer's Handbook has been recreated from the original text files written back in 1992. The maps in the original Handbook were all based on images I provided at the time, which were subsequently re-drawn by a third party. The images in this new edition are scanned versions of the final published maps as I couldn't locate my original image files when I came to create this new edition.

I play-tested Legend (published as *The Four Crystals of Trazere* in the US), wrote the game manual, and had created detailed maps and notes as I went along. These maps and notes formed the basis of the Handbook that Mindscape published 3 months *after* the release of the game. Some of the articles found in the Help & Advice section were provided by the game's authors - Anthony Taglione (Tag) and Pete James. The rest were written by me.

Game solution books were still very much in their infancy back then. Not many games had them, and they were often published months after the game's release to give people time to play the game through on their own. Compare that to today (2007) where we have very glossy, full-colour books packed full of maps, screenshots, tips etc. published on the same day as the game itself!

The layout of this new edition of the Legend Adventurer's Handbook is close but not identical to the originally published book. I called it an 'Adventurer's Handbook' after the impressive Dungeon Master Adventurer's Handbook that FTL had published a few years before, and I liked the title better than calling it a Walkthrough, Solution, or Hintbook. The idea of looking up the answers from numbered paragraphs was inspired by the approach that Level 9 Computing took for their text adventure hint sheets.

Of course, this version is easier to navigate than the original book thanks to the wonders of hyperlinks and bookmarks. You can simply click on a paragraph solution number to be taken directly to it, unless you've printed it off in which case you'll just have to thumb through the solutions the old fashioned way!

Richard Hewison
November 2007

Introduction

The ultimate objective of Legend sounds deceptively easy and straightforward to the uninitiated, but as with all things in life, it isn't quite that simple. Fortunately, help is now at hand. Armed with the knowledge revealed in this tome, you will be prepared for the challenges that await above and below the land of Trazere in your quest for glory.

How this knowledge is used is up to you. Our recommendation would be to seek its wisdom only as a last resort, when all other possible options have been explored and discarded into the pits of despair. However, you can choose to follow the solution through 'step by step', leaving nothing to chance. The only drawback with this method is that feeling of inner satisfaction which comes from completing the quest on your own (with only the occasional and discreet reference to this tome) will be missing when the victory is assured. The choice is yours.

Apart from the level by **level solutions**, there are other sections including **General Strategies**, mini-tips and comprehensive appendices that can be referred to.

THE QUEST

At the start of the adventure, details of the quest are scant. Your party of adventurers must rid the land of evil. How they are to achieve this ultimate goal is a well kept secret, and for good reason as you will discover later on. However, this much can be revealed: to achieve the ultimate ambition of destroying the evil and becoming Legendary, a number of sub-quests will have to be completed that will take the party across the length and breadth of the land. These quests will be difficult, and only those of brave heart, strong steel and powerful magic will survive.

The quest begins in the middle of Trazere. The party are armed only with basic weapons and armour and the steeds that they ride are the slowest and least thoroughbred in the land. Fortunately, there is a town nearby.

A short journey to the south will allow the party to seek refuge in the safe haven of Treihadwyl, a well defended town located in the very heart of Trazere.

Like many other towns and villages throughout Trazere, Treihadwyl has a number of locations to visit within. With only 100 gold pieces each in their possession, there won't be much they can afford to buy from the Blacksmith or Artificer, although a little window shopping can't do any harm to see what is on offer. Eventually they will need to visit the Tavern and talk to the Barkeep. Paying ten gold is often a small amount to pay for the vital knowledge that they can bestow on the party. In this particular instance, you will be told to visit the Guild. From here you can enter the first dungeon.

THE LEVELS

Each level solution has a map which is based on the maps that you can see Elliot draw in the dungeon. However, these maps also mark the location of the all important keys that the party will need to find if they are to progress. The rooms are also numbered and many are described in detail for added reference.

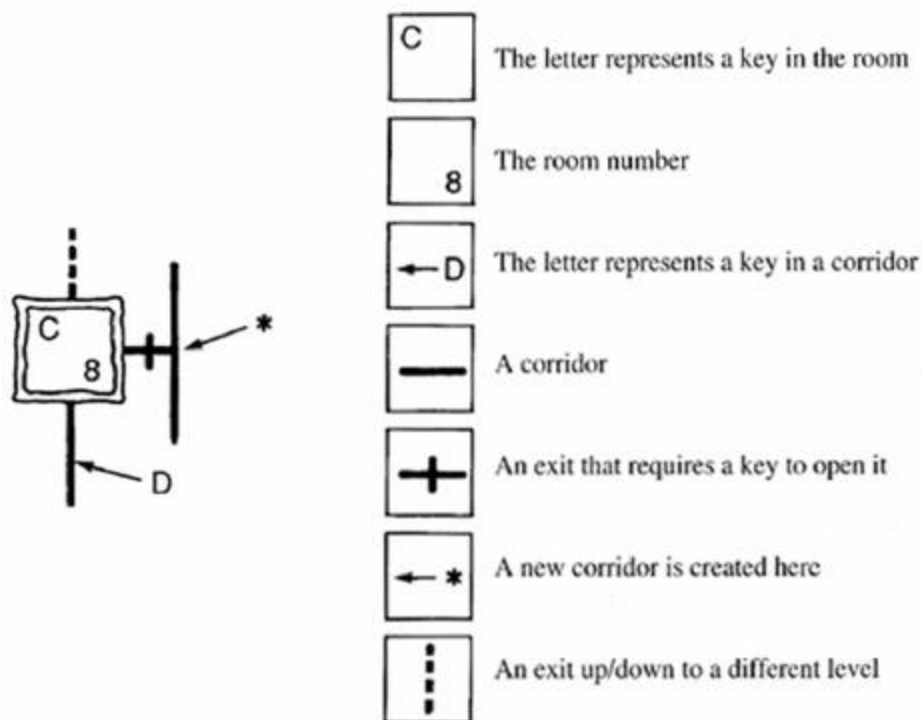

The solutions to the 'puzzle rooms' are not immediately accessible. You will be asked to turn to a particular solution paragraph number to find the answers you seek. Room descriptions that do not have paragraph numbers are described for map reference purposes only and do not contain any puzzles that require solving.

TOOLING UP

Quite often throughout the game, no matter where the party are or what they are doing, there will be times when they need to buy more ingredients, new runes, or train up to new levels of experience etc. The most convenient time to do these tasks is in between dungeon levels (acting as convenient breaks). However, sometimes the need for praying at temples, or buying more ingredients or new runes will not occur at convenient times, and the party will have to flee from what they are doing and return later. The solution given in this tome does not take into account when the tooling up should be done. This is down to the players own judgement of the situation in hand.

However, at the very start of the game it is worth knowing that Smathost, (a village west of the King's castle), has the cheapest ingredients for the first two days of game time. Also available at the Artificer in Smathost is a Golden helm (forward damage), which can give an appreciable experience boost to the Troubadour in your party. This item only becomes available after you have made your first visit to the Guild in Treihadwyl.

It is recommended that before you follow the solution, you take a glance at the [General Strategies](#) section. This will give you invaluable tips that can be used throughout the game.

Treihadwyl - Level 1

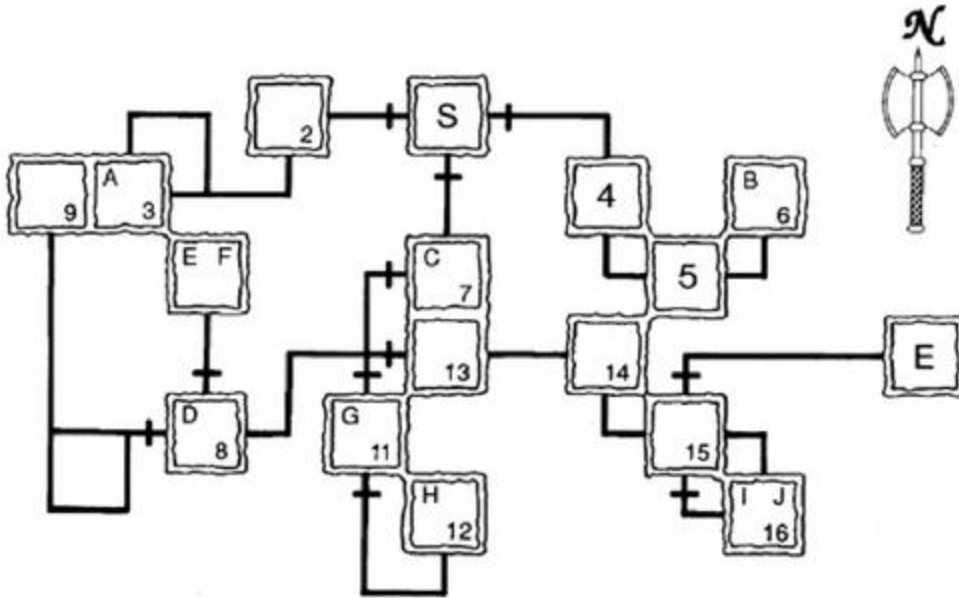

KEY	Located at	Opens
(A) AZURE	Room 3	Door inside room 9
(B) CRYSTAL	Room 6	S door, Start room
(C) IRON	Room 7	W door, room 7
(D) BRONZE	Room 8	W door, room 8
(E) RUBY	Room 10	N door, room 15
(F) EMERALD	Room 10	S door, outside room 11
(G) BRONZE	Room 11	S door, room 11
(H) SILVER	Room 12	E door, outside room 13
(I) CRYSTAL	Room 16	S door, room 15
(J) TOPAZ	Room 16	Door inside room 16

Treihadwyl - Level 1 (of 2)

Beneath the Guild is a cellar, and this is the party's first taste of dungeoneering. The Cellar has been designed by the Guild as a test to see if the party are worthy. To date, no one has returned from this dungeon with the permit that will allow them to seek an audience with the King.

The Room details

S - This is the start room where you enter or leave the level. [67]

8 - A room with three double floor spikes, two levers and one button. A sign reads "A key in a clock..." [105]

9 - A room with two double spikes, a pillar and some levers. [48]

11 - There is a damage rune on the floor in front of a pillar, blocking access to the W side of the room. [81]

13 - This is a regeneration room. The sign says "Reforge thy bones" [23]

14 - The nearby sign reads "Barkeeps are your eyes..."

15 - An unreachable N door is in this room. The sign says "Great cunning..." [113]

16 - There are two halves to this room. A pillar lever occupies the W side. A door lies in the E side with a button behind it. An unreachable chest sits in the NW corner. [59]

E - This is the exit room from level 1 to level 2 of Treihadwyl. The sign nearby begins "The stalwart men of the keeps..."

Treihadwyl - Level 2

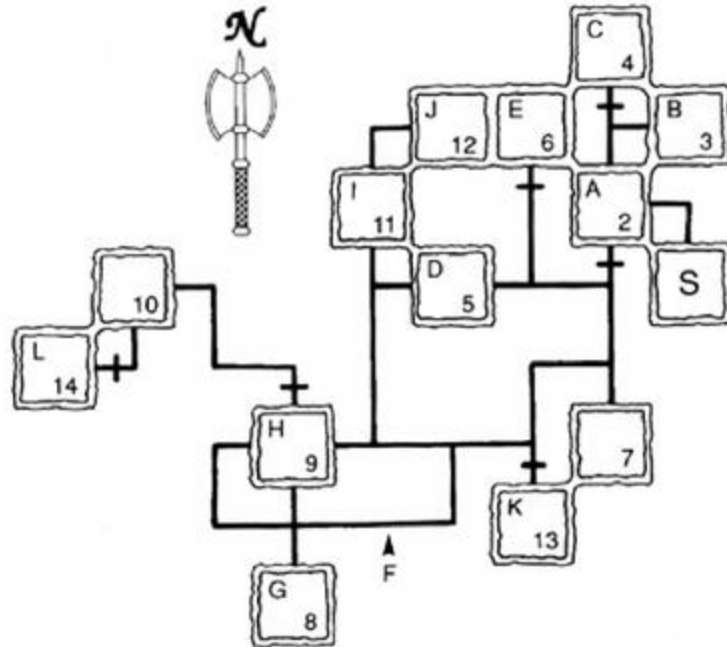

KEY	Located at	Opens
(A) ORNATE	Room 2	Door within room 4
(B) GOLD	Room 3	N door, outside room 4
(C) AZURE	Room 4	S door, room 2
(D) IRON	Room 5	N door, outside room 6
(E) ORNATE	Room 6	Door within room 4
(F) BRONZE	Near Room 8	S door, room 13
(G) DIAMOND	Room 8	N door, room 9
(H) SILVER	Room 9	W door, outside room 14
(I) CRYSTAL	Room 11	N door, room 11
(J) ORNATE	Room 12	Door within room 4
(K) ORNATE	Room 13	Door within room 4
(L) ORNATE	Room 14	E door, room 2

Treihadwyl - Level 2 (of 2)

This level contains the permit you need to visit the King. You will come across the room with the permit quite quickly, but four sets of double floor spikes block the way. A room nearby has four buttons which will remove the spikes.

The Room details

2 - In this room are some double floor spikes and a blue button in the SW corner. There is also a chest and a skull like floor tile on the ground. The Party is split up and teleported to different areas on first entry into the room. The E door locks when the chest is approached. [31]

3 - This is the Permit room. The path to the permit is blocked by four sets of spikes. The permit is in the middle of this room at the end of path. The sign begins "You are cordially invited..."

4 - Here are four doors with four buttons, one behind each door. [95]

8 - This room contains a number of double floor spikes. [126]

10 - Here is a puzzle room with lots of water, a separate 'island' on its own and some runes on the floor. [72]

11 - This room has two levers and two teleport tiles on the floor. The sign reads "Send a friend". [101]

What to do on finishing the level? [8]

Fagranc - Level 1

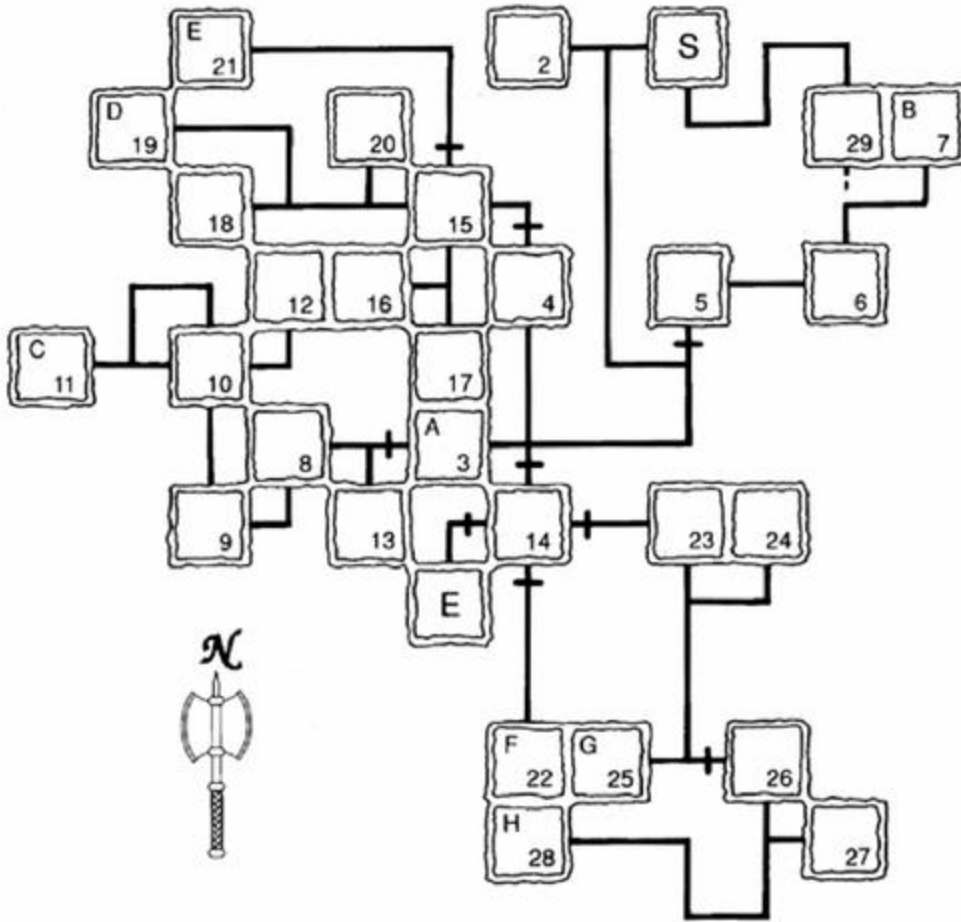

KEY	Located at	Opens
(A) AZURE	Room 3	N door outside room 5
(B) EMERALD	Room 7	W door, room 3
(C) SILVER	Room 11	S door, outside room 14
(D) CRYSTAL	Room 19	N door, room 15
(E) BRONZE	Room 21	S door, room 14
(F) GOLD	Room 22	E door, room 14
(G) IRON	Room 25	E door, outside room 26
(H) DIAMOND	Room 28	W door, room 14

Fagranc - Level 1 (of 8)

The gates of Fagranc should be opened with the key given to the party by the King. Selection option 1 and the key will unlock the gates and disappear. Now select option 1 again to enter.

The Room details

Need to know which additional runes you will need in this dungeon? [39]

S - This is the start room. The sign begins "Beyond these doors..."

1 - The sign here reads "Arcane lore tells of a magic shrine..."

4 - This is a large open room with a blue square floor switch and a green square floor switch on the E side. A chest is in the NW area near the exit. [87]

13 - This is a regeneration area. The sign says "Reforge they bones"

28 - This is another devious puzzle room with three pillar levers, a shooting pillar, a chest, a normal pillar and a number of runes on the floor as well as three separate teleport squares. [14]

29 - How do you reach this room? [110]

Fagranc - Level 2

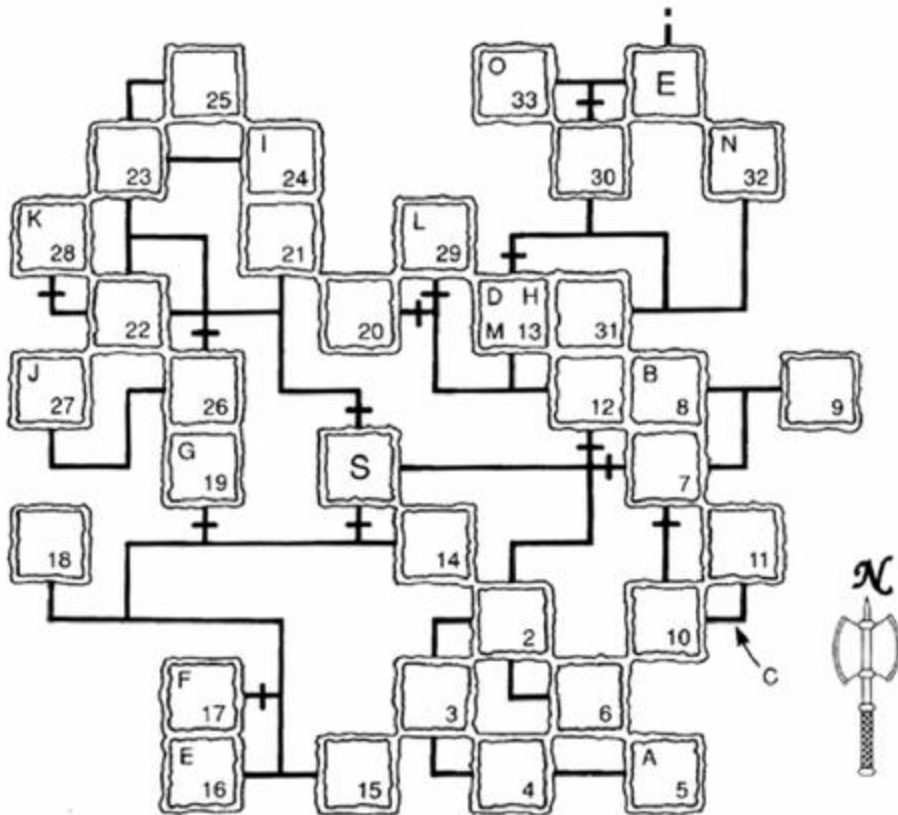

KEY	Located at	Opens
(A) GOLD	Room 5	W door, outside room 7
(B) BRONZE	Room 8	S door, room 7
(C) CRYSTAL	Near room 10	N door, outside room 12
(D) AZURE	Room 13	S door, Start room
(E) ORNATE	Room 16	W door, outside room 17
(F) DIAMOND	Room 17	N door, outside room 19
(G) SILVER	Room 19	W door, outside room 20
(H) EMERALD	Room 13	N door, Start room
(I) IRON	Room 24	S door, outside room 26
(J) SILVER	Room 27	N door, outside room 28
(K) TOPAZ	Room 28	N door, outside room 29
(L) IRON	Room 29	Door within room 29
(M) CRYSTAL	Room 13	N door, room 13
(N) RUBY	Room 32	N door, room 30
(O) SKULL	Room 33	E door, outside Exit room

Fagranc - Level 2 (of 8)

Fight your way through this level, vanquishing as much evil as possible.

The Room details

Want to know which additional runes are needed for this level? [61]

13 - This room has a set of double floor spikes, a chest and a N door. The sign begins "A block of stone..."

16 - Characters are teleported to the four corners of the room if they approach the chest in this room. [33]

20 - There is a lever in this room. [10]

29 - There is a chest here, and three teleport pads on the floor. A teleport tile is in front of the chest. A red button is located behind a door. [131]

30 - The sign reads "The fathomless depths..."

E - This is the exit room, with a N exit which leads to level 1 and a S exit which leads to level 3.

What to do now? [99]

Dark Tower - Level I

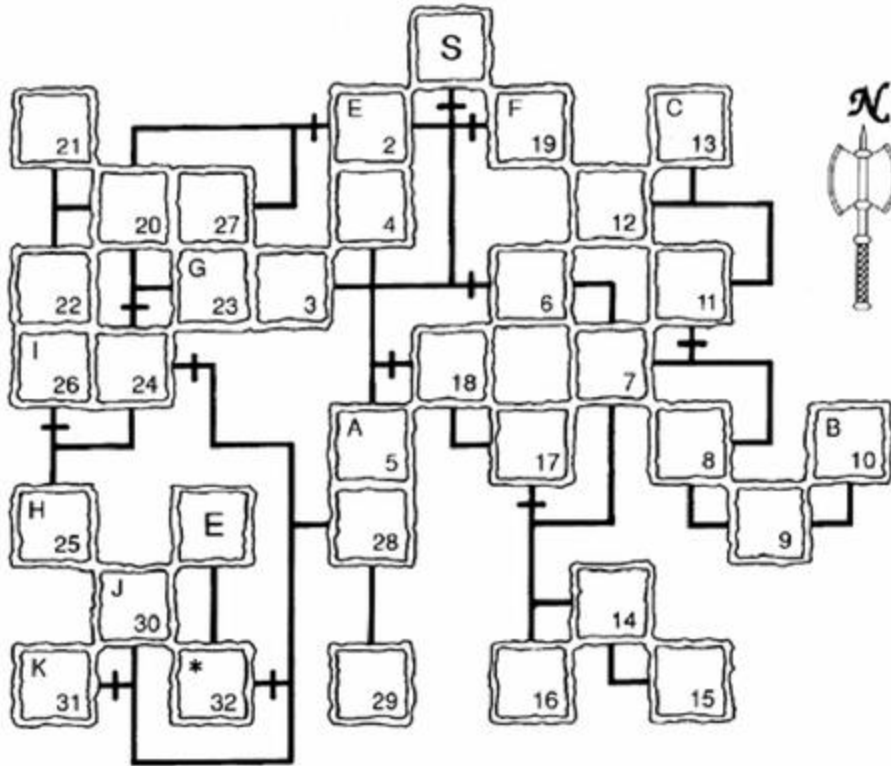

KEY	Located at	Opens
(A) RUBY	Room 5	E door, outside room 6
(B) BRONZE	Room 10	N door, outside room 11
(C) DIAMOND	Room 13	S door, room 7
(D) SILVER	Room 15	N door, outside room 17
(E) IRON	Room 2	E door, outside room 19
(F) CRYSTAL	Room 19	W door, room 2
(G) AZURE	Room 23	N door, room 24
(H) TOPAZ	Room 25	N door, outside room 26
(I) EMERALD	Room 26	E door, room 24
(J) BRONZE	Room 30	W door, outside room 31
(K) GOLD	Room 31	W door, outside room 32

The Dark Tower - Level 1 (of 5)

Need to know which additional runes you need for this level? [1]

How do I get into the Tower? [75]

The Room details

S - This is the starting room. Also see [75].

2 - A firepit divides this room. The door here won't budge. [52]

18 - This is the secret garden room. A set of double floor spikes divides the room in two (N/S). There is a rune on the floor in the NE corner. A square green floor switch lies near to the NW door. The sign on the pillar near the chest reads "So you've found my secret garden...". A lever is also nearby. [119]

31 - A room that looks like a library. [74]

32 - Another taxing puzzle room. How do you get to the other side? [19]

E - The exit room from this level. The sign reads "See you at the top!"

Dark Tower - Level 2

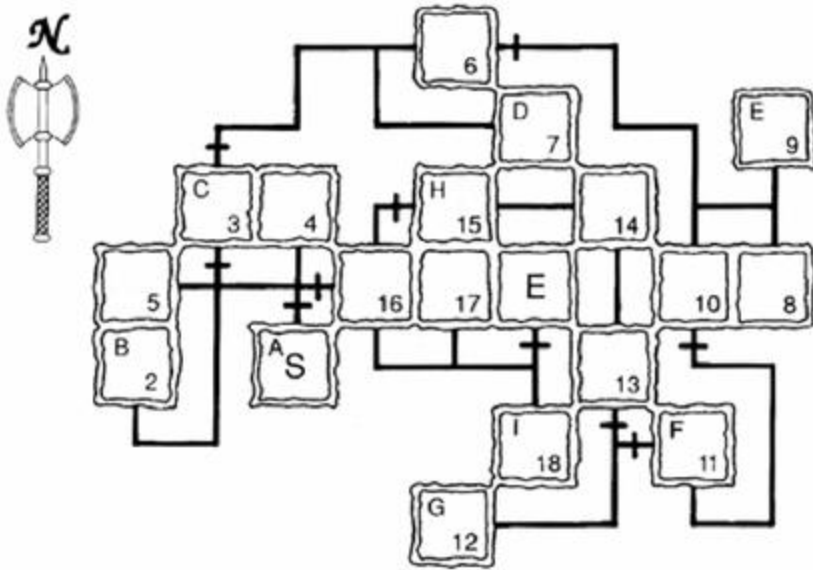

KEY	Located at	Opens
(A) CRYSTAL	Start room	Opens N door, start room
(B) DIAMOND	Room 2	N door, outside room 3
(C) BRONZE	Room 3	N door, room 3
(D) RUBY	Room 7	E door, room 6
(E) EMERALD	Room 9	S door, room 10
(F) SILVER	Room 11	W door, room 11
(G) AZURE	Room 12	N door, outside room 13
(H) TOPAZ	Room 15	W door, room 15
(I) GOLD	Room 18	N door, outside exit room

The Dark Tower - Level 2 (of 5)

Continue your race to get to the top of the tower.

The Room details

Want to know what new runes you need on this level? [106]

S - The start room

2 - The sign here begins "Anything that vanishes..."

3 - There is a lever in this room, and a pillar with a red button on it surrounded by a set of double floor spikes. [29]

11 - Fireballs are launched from the nearby pillar in this room if anyone stands on the square tile in front of the chest. The sign says "A taste of what is to come." [44]

14 - Another tricky puzzle room. There are four consecutive doors lined up in a row. A monster is behind each of the first three. There are four damage runes in a row, and a 5th E of the room behind a pillar. [130]

16 - How do you open the W door? [82]

E - The exit room.

Dark Tower - Level 3

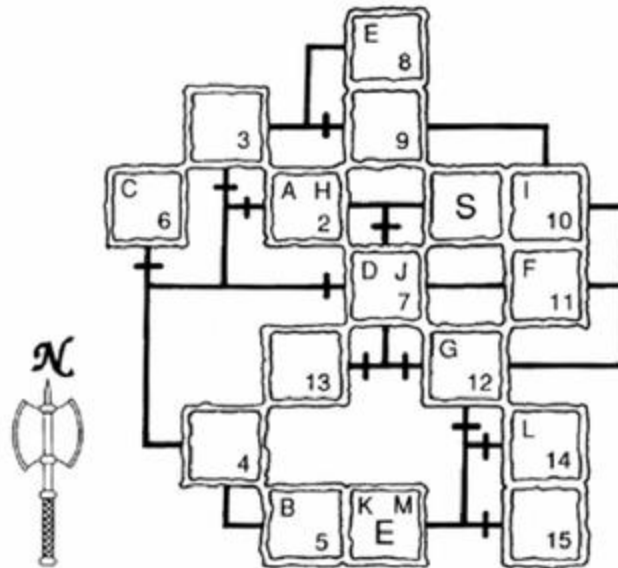

KEY	Located at	Opens
(A) RUBY	Room 2	W door, room 2
(B) IRON	Room 5	N door, outside room 6
(C) TOPAZ	Room 6	E door, outside room 7
(D) RUBY	Room 7	N door into second half of room 3
(E) BRONZE	Room 8	E door, outside room 9
(F) EMERALD	Room 11	W door, room 12
(G) AZURE	Room 12	Door inside room 10
(H) SILVER	Room 2	W door, outside room 13
(I) GOLD	Room 10	Door inside room 11
(J) CRYSTAL	Room 7	S door, room 12
(K) DIAMOND	Exit room	E door, outside room 14
(L) DARK	Room 14	E door, outside room 15
(M) ORNATE	Exit room	Door inside Exit room

The Dark Tower - Level 3 (of 5)

Only two more levels to go before you reach the top!

The Room details

S - The Start Room.

3 - This room is divided into two halves (E/W). There are two doors within. The W side is locked and contains a lever.

7 - The room is divided into three distinct areas. There is a sign and a chest on the S side. The sign reads "Short cut back". [2]

10 - There is a locked door within this room. [63]

11 - There is a lever behind a door in here. [92]

13 - This is a dead end with a lever. [85]

14 - Another devious puzzle room. You need to reach the NE chest and get the key from inside. There is a group of four runes on the floor and some more surrounding a shooting pillar in the N/NW corner of the room. A nearby cauldron contains lots of spell ingredients! [107]

15 - There is a blue button in here. [120]

E - This is the exit room. The isolated chest in the middle cannot be reached. [9]

Dark Tower - Level 4

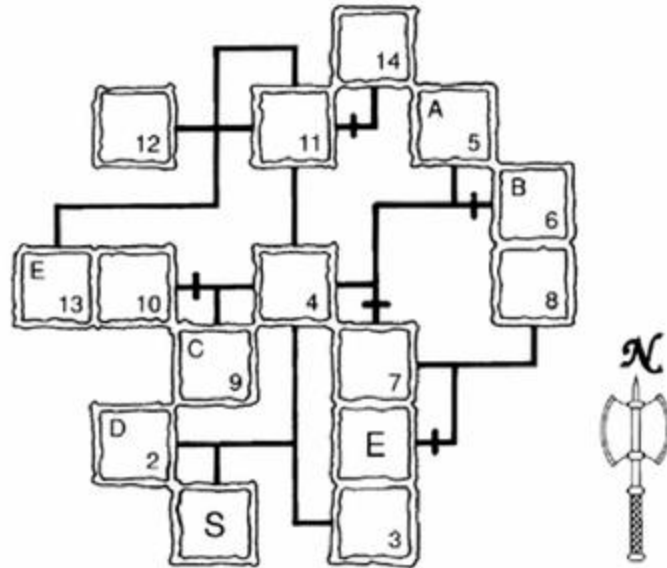

KEY	Located at	Opens
(A) BRONZE	Room 5	E door, outside room 6
(B) SILVER	Room 6	S door, outside room 7
(C) CRYSTAL	Room 9	Door inside room 2
(D) DIAMOND	Room 2	W door, outside room 10
(E) IRON	Room 13	E door, room 11
(F) GOLD	Room 12	W door, outside Exit room

The Dark Tower - Level 4 (of 5)

A smaller level than before.

The Room details

S - The Start room.

2 - There is a locked door inside this room. [30]

3 - The lever in this room is blocked by a double set of floor spikes. [66]

4 - This room is split into two halves by a stream of water. [43]

8 - There is a lever in here. [98]

10 - There is another lever in this room. [122]

12 - There is an unreachable yellow floor switch in this location. Two pillars stand in the NW corner. One has a sign on it which reads "Things to do...". There is something behind the pillars. [3]

13 - There is lever in here. [80]

14 - There is a lever in this room. [133]

E - The exit room from this level.

Want to know more about the levers? [55]

Dark Tower - Level 5

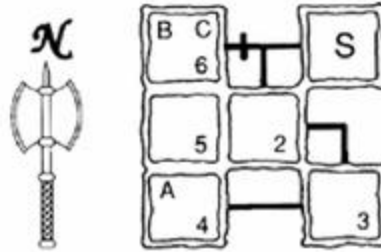

KEY	Located at	Opens
(A) DARK	Room 4	W door, room 2
(B) CRYSTAL	Room 6	E door, room 6
(C) SKULL	Room 6	Fagranc - Level 3

The Dark Tower - Level 5 (of 5)

A very small level which contains the evil Runemaster Kilijan. Make sure your Runemaster is well stocked up with spells and ingredients.

Warning: Kilijan is immune to Paralyze and Disrupt!

The Room details

What additional runes do you need on this level? [27]

S - The start room.

2 - The sign in here reads "Trespassers will be vaporised."

5 - A sign begins "I came from the South..."

6 - This is Kilijan's chamber! [20]

Want to know what to do once Kilijan is defeated? [104]

This page is intentionally left blank

Fagranc - Level 3

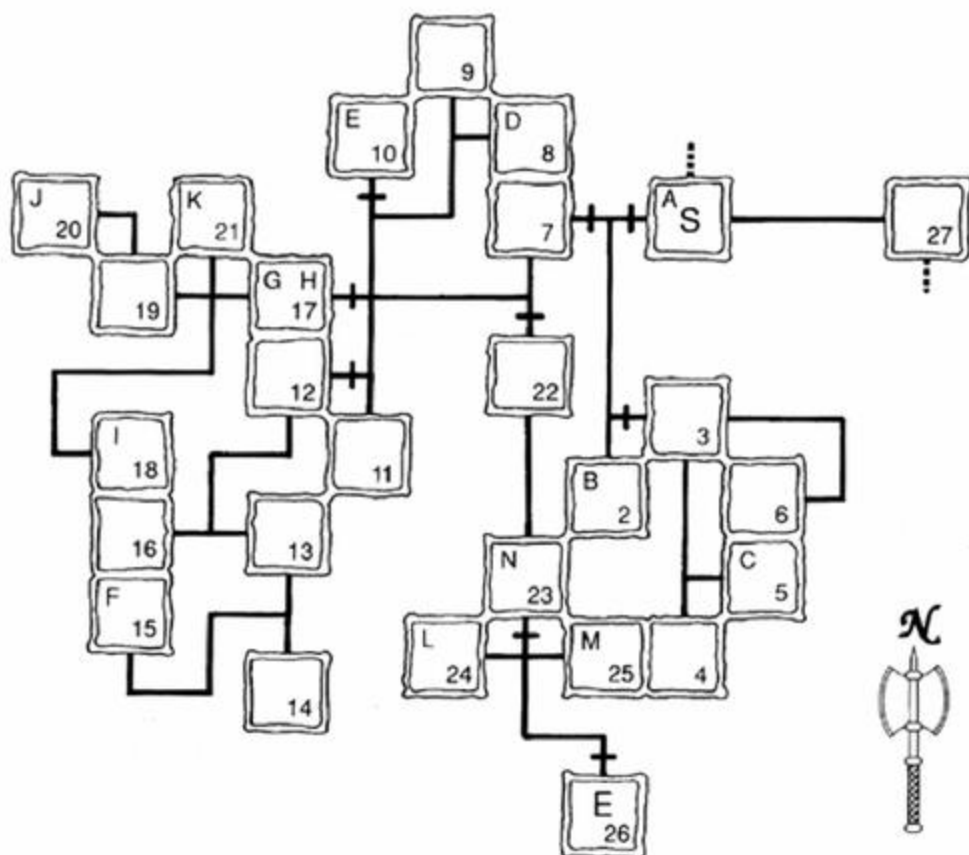

KEY	Located at	Opens
(A) DARK	Start room	The Dark Tower - Level 1
(B) BRONZE	Room 2	E door, outside room 3
(C) EMERALD	Room 5	W door, outside room 7
(D) IRON	Room 8	N door, outside room 10
(E) SILVER	Room 10	W door, outside room 12
(F) GOLD	Room 15	W door, outside room 17
(G) DIAMOND	Room 17	Door inside room 17
(H) CRYSTAL	Room 17	W door, room 17
(I) ORNATE	Room 18	Door inside room 7
(J) ORNATE	Room 20	Door inside room 7
(K) GOLD	Room 21	E door, room 17
(L) IRON	Room 24	Door inside room 25
(M) SILVER	Room 25	Door inside room 24
(N) AZURE	Room 23	S door, outside Exit room

Fagranc - Level 3 (of 8)

Using the Great Stairs, nip back down to the door which leads to the third level. The skull key from the Dark Tower is used to open the first door in the Start room.

The Room details

S - The Start room. A sign says "Come and see..." [50]

7 - Two blue buttons, each behind a locked door. [12]

17 - This is a tricky puzzle room. You need to reach the W exit. [127]

22 - A room with two halves, each with a lever. [111]

23 - This room is split into two halves which are entered via separate doors. The S door outside is locked. [65]

24 - There are two doors here, each with a lever behind. The W side of the room is inaccessible. There are also doors which are unreachable in the NE corner. [91]

25 - This room has two doors with a lever behind each. The nearest door is reachable. [93]

27 - How do you get to this room? [4]

Fagranc - Level 4

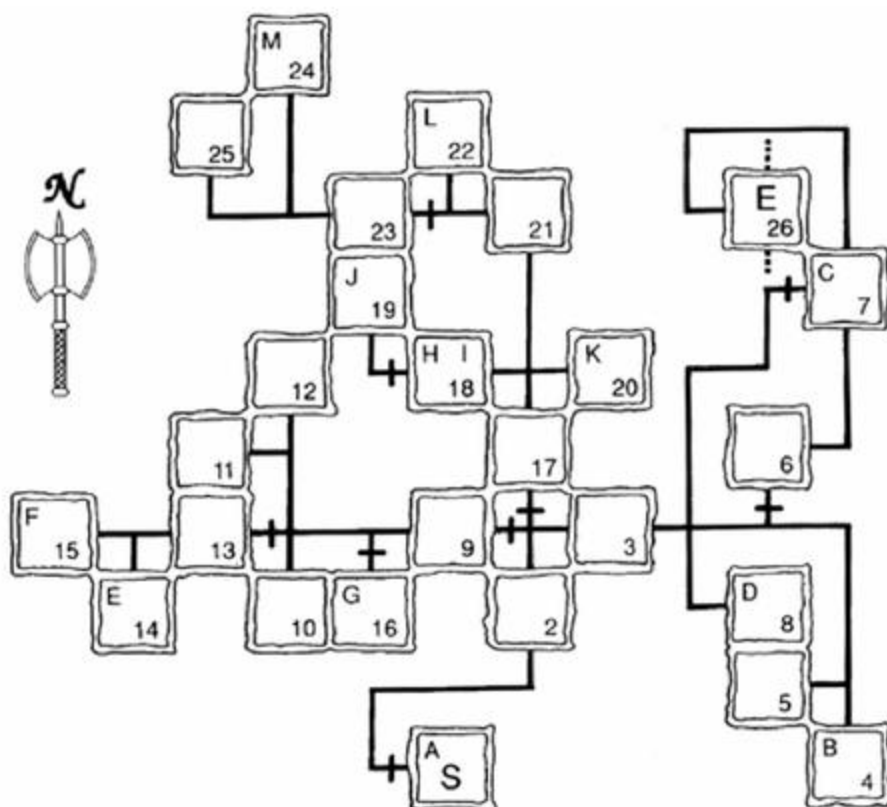

KEY	Located at	Opens
(A) DIAMOND	Start room	W door in Start room
(B) BRONZE	Room 4	N door, outside room 6
(C) CRYSTAL	Room 7	W door, outside room 9
(D) GOLD	Room 8	Door inside room 2
(E) IRON	Room 14	S door, outside room 16
(F) GOLD	Room 15	Door inside room 2
(G) AZURE	Room 16	N door, outside room 17
(H) EMERALD	Room 18	Door inside room 18
(I) RUBY	Room 18	E door, room 18
(J) SILVER	Room 19	Door inside room 20
(K) GOLD	Room 20	Door inside room 2
(L) TOPAZ	Room 22	W door, outside room 23
(M) GOLD	Room 24	Door inside room 2
(N) ORNATE	Room 2	E door, outside room 7
(O) TOPAZ	Room 11	W door, outside room 13

Fagranc - Level 4 (of 8)

The main quest in this level is to open the consecutive doors in room 2.

The Room details

S - The Start room.

2 - Here are four consecutive doors with a chest behind the last one. [68]

7 - There are two sets of double floor spikes here. The NE pillar has a lever on it. The SW pillar also has a lever, which is accessed by the W door. There are two doors to the N, and a chest in NW corner.

11 - This small room has four skull tiles on the floor and a yellow floor button which prevents progress to a chest. Anyone who stands on the switch is teleported back to the E side of the room. [36]

18 - This room has a large water area in the middle. Two chests stand on tiles surrounded by the water. There is a lever on a pillar in the S area and a button on a pillar to the N. [129]

20 - The sign here says "Tetrahaael - Lord of Chaos..."

E - This is the Exit room. It has N and S exits which lead up or down to different levels.

Want to know what you should do next? [73]

Balenhalm - Level 1

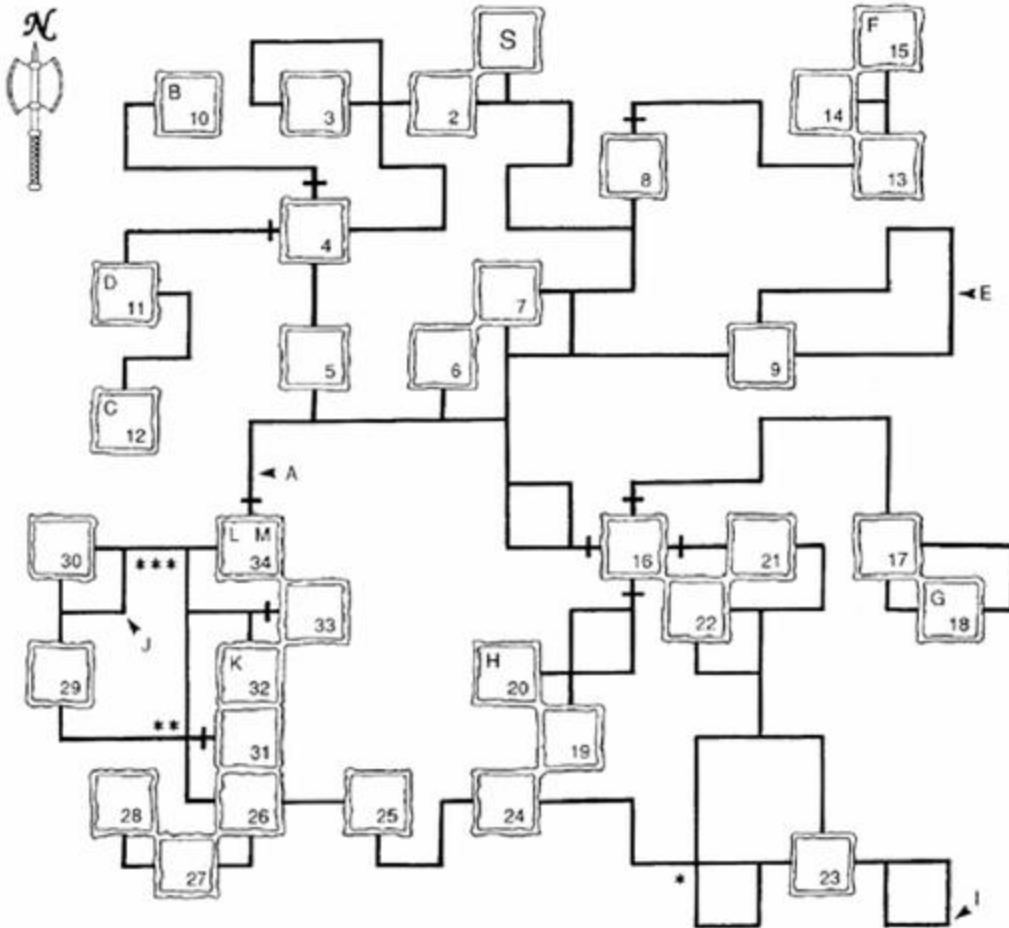

KEY	Located at	Opens
(A) GOLD	Near room 34	N door, room 4
(B) CRYSTAL	Room 10	W door, room 4
(C) SILVER	Room 12	Door inside room 11
(D) BRONZE	Room 11	N door, room 16
(E) IRON	Near room 9	N door, room 8
(F) RUBY	Room 15	E door, outside room 16
(G) DIAMOND	Room 18	S door, room 16
(H) AZURE	Room 20	E door, room 16
(I) TOPAZ	Near room 23	Door inside room 23
(J) CRYSTAL	Near room 30	E door, outside room 31
(K) GOLD	Room 32	E door, outside room 33
(L) EMERALD	Room 34	Door inside room 34
(M) MOON	Room 34	Moonhenge - Level 1

Balenhalm - Level 1 (of 1)

There is only one level of sewers beneath Balenhalm, but the corridors are long and winding down there. The quest in this level is to locate and take back the serpent crystal. This is the first of four such crystals to be recovered in the remainder of the game.

The Room details

S - The start Room. A sign begins "The foul stench..."

11 - There is a locked door in here. [60]

4 - This is a nasty room to get caught in a fight due to its design and the number of available exits.

23 - There is a pillar lever in the middle of the room, behind a locked door. [90]

24 - There is one set of floor spikes in this room, and eight teleport pads (3 orange, 3 red and 2 green). There is also a pillar in the NW corner with a red button. How do you reach the W door? [22]

31 - There are three shooting pillars lined up on the N side in this room. Opposite each one is a round red floor switch. In the NE corner is a door and behind it a pillar with a lever. A square red floor switch is in the SE corner. A chest and another long chest stand in the SW corner (presently unreachable). [132]

33 - A chest stands between two pillars in the middle of the room. The right hand pillar has a lever. A red square floor switch stands on the right side and a blue one is located nearer to the chest. [41]

32 - This room is divided into N/S halves. There is a red pillar button in the S side. [6]

34 - The Serpent Crystal is in this room.

Want to know what to do now? [76]

Moonhenge - Level 1

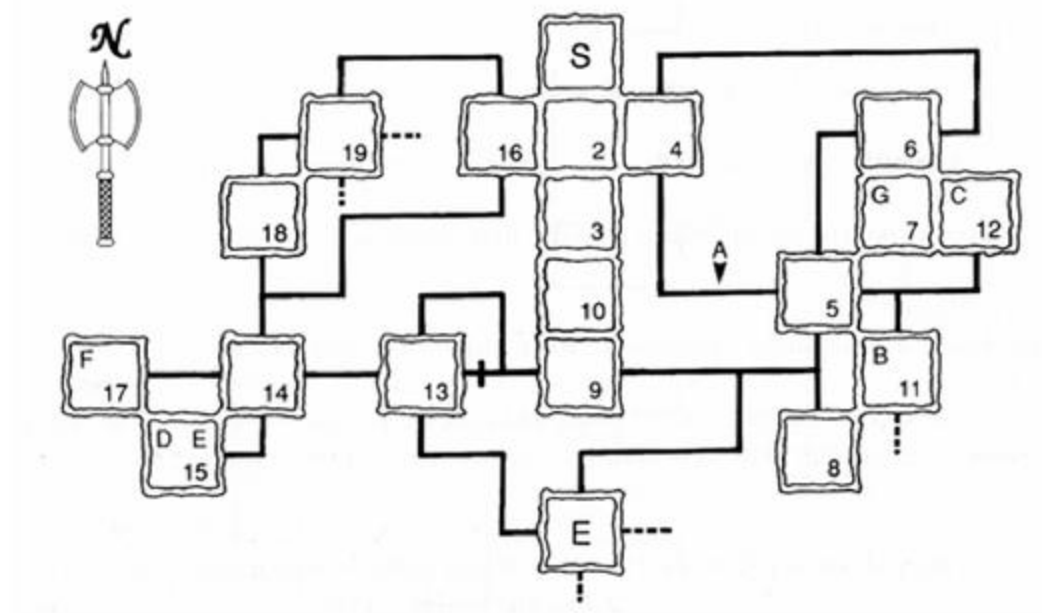

KEY	Located at	Opens
(A) CRYSTAL	Near room 5	Door within room 4
(B) SILVER	Room 11	Door inside room 12
(C) AZURE	Room 12	Door inside room 3
(D) BRONZE	Room 15	Door inside room 15
(E) EMERALD	Room 15	W door, outside room 13
(F) IRON	Room 17	Door inside room 18
(G) CRYSTAL	Room 7	Door to room 17 on level 2

Moonhenge - Level 1 (of 2)

Moonhenge is a confusing dungeon to explore, even when you understand what is happening and what you have to do. Navigating your way through each room or corridor isn't as straightforward as before, because up to four different and unconnected paths can go through the same room. Working out how to get to the room you want isn't as simple as following the correct path on the in game map.

Need a general tip for surviving Moonhenge? [117]

How do you enter the dungeon? [24]

The Room details

S - You start outside the dungeon in the wilderness.

5 - This room will always contain a dead end, but not necessarily the same one each time! [51]

7 - In this room lies the Moon Crystal (a blue gem). The room is divided into two levels. [100]

8 - This room is shaped like a horse shoe and contains a pillar lever behind a door. [79]

11 - There is a pillar lever behind a door that "will not budge". There is a stairs exit to the S. [123]

12 - There is a locked door inside this room. [17]

14 - There is a red button on a pillar in here. [64]

13 - The N and W exits are on a higher level than the S and E exits.

Moonhenge - Level 2

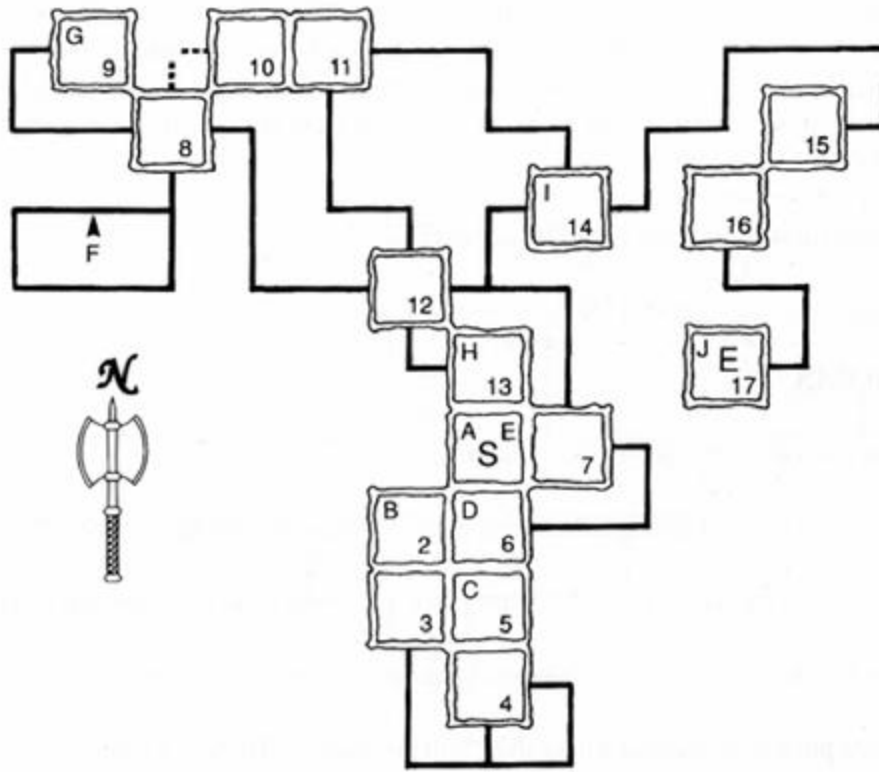

KEY	Located at	Opens
(A) RUBY	Start room	Used on Level 1
(B) DARK	Room 2	Door within room 2
(C) AZURE	Room 5	Door inside room 6
(D) SILVER	Room 6	Door inside room 6
(E) GOLD	Room 2	Used on Level 1
(F) BRONZE	Near room 8	Door within room 8
(G) DIAMOND	Room 9	Used on Level 1
(H) RUBY	Room 13	Door inside room 10
(I) MOON	Room 14	Northern door, Start room
(J) SKULL	Room 17	Used on Fagranc Level 5

Moonhenge - Level 2 (of 2)

A nightmare to map and to navigate through. It is connected with Level 1 in more ways than you think!

The Room details

S - Start room. There are two doors, one that "...will not budge". [88]

8 - This room has a pillar lever and three paths with doors. [108]

11 - There is a locked door within this room. [5]

14 - The door in here won't budge. There is a pillar lever in the SE corner. [49]

17 - A sign reads "You cannot defeat us..."

What do you do when Moonhenge has been completed? [26]

Fagranc - Level 5

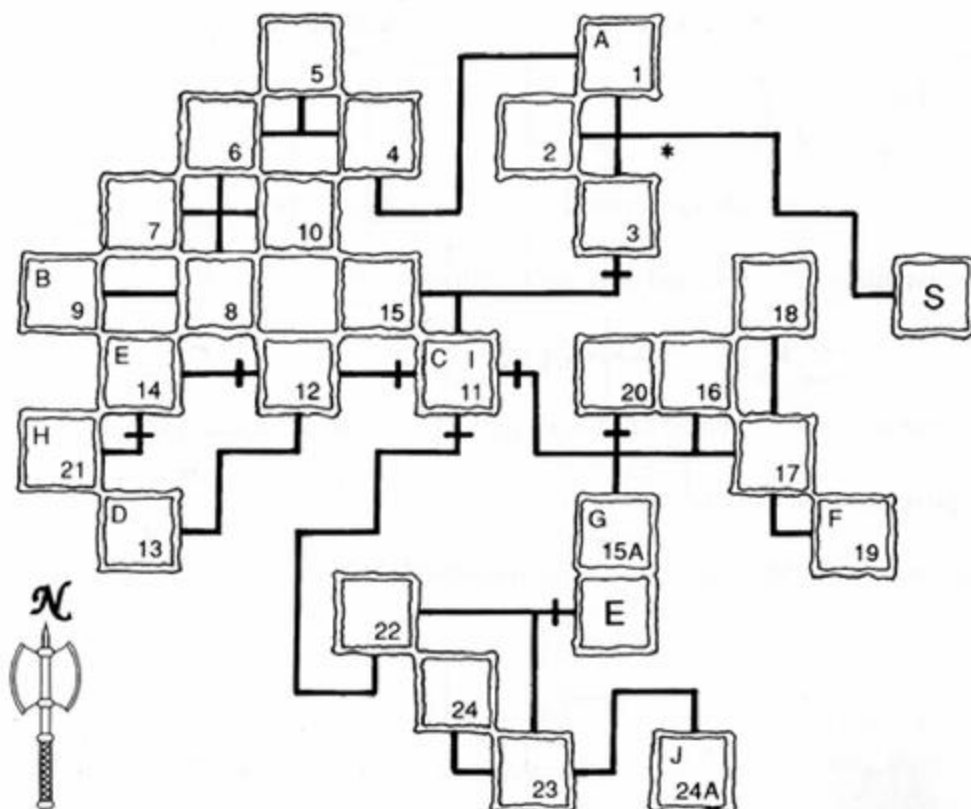

KEY	Located at	Opens
(A) GOLD	Room 1	Door inside room 2
(B) IRON	Room 9	S door, room 3
(C) CRYSTAL	Room 11	W door, room 11
(D) SILVER	Room 13	W door, room 12
(E) AZURE	Room 14	E door, room 11
(F) BRONZE	Room 19	Door inside room 15a
(G) RUBY	Room 15a	N door, outside room 20
(H) DARK	Room 21	Door inside room 11
(I) EMERALD	Room 11	S door, room 11
(J) DIAMOND	Room 24	E door, outside Exit room

Fagranc - Level 5 (of 8)

Go down the "Great Stairs" from level 1 to level 5 and you're ready to open the door with the Skull key from Moonhenge.

The Room details

S - The start room. The W door requires the SKULL key from Moonhenge Level 2.

* - The sign here begins "Merchants storerooms..."

2 - There is a locked door within this room. [69]

4 - In this room you can see four round red floor switches in the NE corner and three teleport pads on the E side. There is also a trench of fire in the floor and a pillar lever in the NW corner. Some floor spikes prevent access to the lever or the switch in here. [35]

11 - A devious puzzle room. There is one red, one green, one yellow and one blue round floor switch in here. A square green floor switch lies in the NW corner behind a door. [128]

14 - There is a pillar lever and a blue pillar button in this room. A yellow switch lies on the floor. You have to step on the switch to approach the button, and when you do a pillar will appear in front of the button. The pillar lever doesn't do anything when pulled and the S door "...won't budge". [13]

15a - There is a locked door within this room. [57]

20 - There is a pillar lever in here and a sign which begins "A lever is broken..." [112]

Fagranc - Level 6

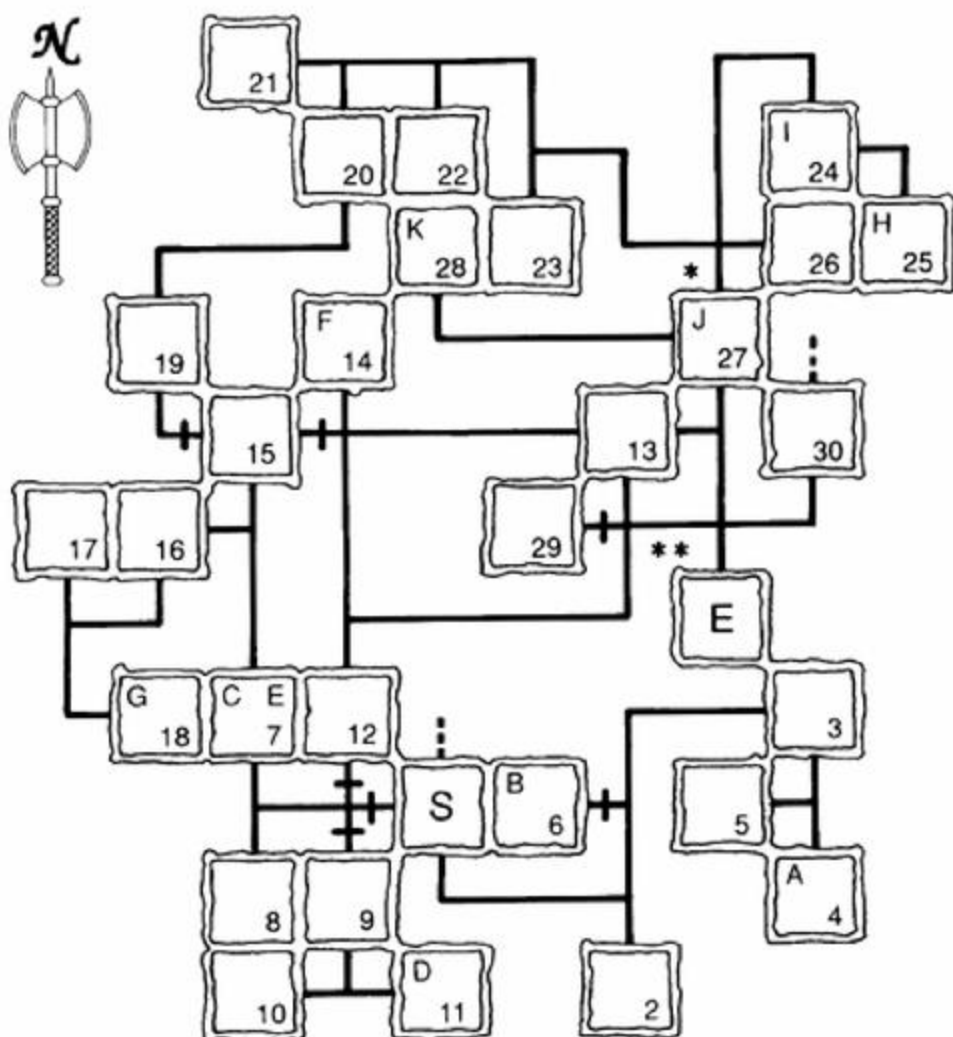

KEY	Located at	Opens
(A) TOPAZ	Room 4	W door, outside room 6
(B) BRONZE	Room 6	W door, Start room
(C) RUBY	Room 7	S door, outside room 9
(D) CRYSTAL	Room 11	Door within room 7
(E) DIAMOND	Room 7	N door, outside room 12
(F) EMERALD	Room 14	W door, outside room 15
(G) AZURE	Room 18	W door, room 15
(H) GOLD	Room 25	Door inside room 24
(I) SILVER	Room 24	Door inside room 26
(J) IRON	Room 27	W door, room 27
(K) ORNATE	Room 28	W door, outside room 29

Fagranc - Level 6 (of 8)

This level of Fagranc ends at the "Great Stairs" instead of starting there so you must solve the entire level to reach it. This means that until you complete the level, you will have a long journey back to the staircase at the start of level 5 to get back outside if you need to tool up on anything.

The Room details

S - The start room. The sign here reads "A room you seek..."

7- There is a locked door in here. [89]

14 - There are three levers on three separate pillars lined up in water to the N in this room. A teleport pad is in front of each one. A chest stands in the NE corner and there is another pillar lever in the SW corner. There are also two green pads, one red pad and another chest in the S side of room. [11]

24 There is a locked door in this room. [40]

26 - There is a pillar lever in this room. The sign here reads "The tomb of Sir Ptedren Incatlathar". [32]

28 - This room has four buttons (red, green, blue and orange). A chest stands in the NW corner blocked by floor spikes. [96]

29 - There are two fire trenches in the floor here. A yellow pillar button stands nearby, as does a chest and a table. [124]

30 - Back at the Great Stairs.

E - This is the exit room to Level 7.

What do you do once level 6 has been solved? [7]

The Unshrine - Level 1

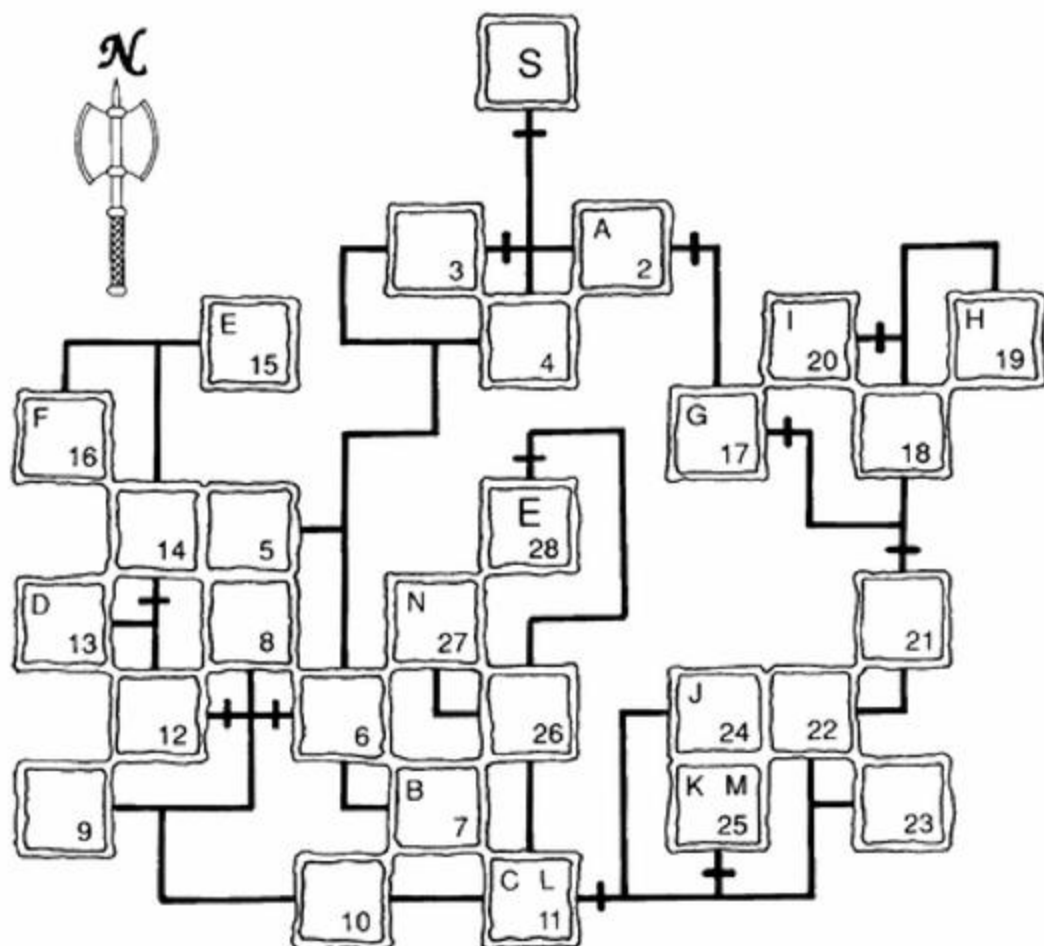

KEY	Located at	Opens
(A) CRYSTAL	Room 2	W door, outside room 3
(B) IRON	Room 7	W door, room 6
(C) AZURE	Room 11	W door, outside room 12
(D) BRONZE	Room 13	N door, outside room 14
(E) DARK	Room 15	E door, room 2
(F) ORNATE	Room 16	Door inside room 11
(G) SILVER	Room 17	E door, room 17
(H) CRYSTAL	Room 19	W door, outside room 20
(I) GOLD	Room 20	S door, outside room 21
(J) EMERALD	Room 24	N door, outside room 25
(K) RUBY	Room 25	W door, outside room 11
(L) TOPAZ	Room 11	Door inside room 25
(M) ORNATE	Room 25	Door inside room 11
(N) UNKEY	Room 27	S door, outside Exit room

The Unshrine - Level 1 (of 2)

The mysterious Unshrine manifests itself every Beamday, but no one knows where it will appear next, or do they? You must get inside the Unshrine and defeat an evil Chaos Lord...

How do you know where the Unshrine will appear? [46]

How do you get inside the Unshrine? [71]

Which additional spells are needed within? [103]

The Room details

S - This is the start room. [21]

2 - A floor switch lies in the middle of the room. When stepped on, a stream of healing bolts are launched. The sign here reads "Heal thy wounded".

3 - The yellow floor switch in middle of this room activates fireballs of damage. The sign says "None shall pass this fiery blast". [62]

11 - There are two halves to this room. Two doors stand in the E half of the room. [18]

12 - This room has two distinct halves (N and S). A teleport pad and some teleport runes lie on the floor. There are two runes on the other side (Teleport and Make Weapon). [94]

25 - This is another puzzle room. There are three pillar buttons in here and a SE door inside the room. Teleport runes are on the floor and a pillar lever stands in the NW corner along with a chest guarded by some double floor spikes. [37]

26 - There are two halves (E and W) to this room. There is a pillar lever and a pillar button. [118]

E - The Exit room. The sign begins "Descend into the pit..."

What should you do before entering the next level? [42]

The Unshrine - Level 2

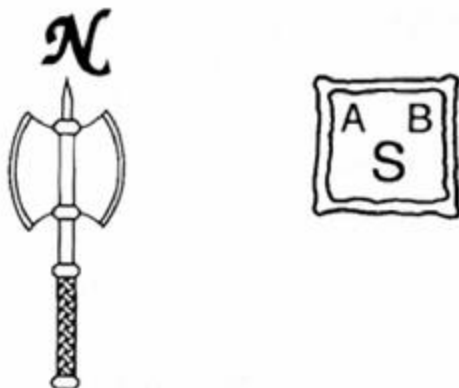

KEY	Located at	Opens
(A) SKULL	Start room	Fagranc - Level 7
(B) UNKEY	Start room	Door inside start room

The Unshrine - Level 2 (of 2)

There is only one room to level 2 and it contains the Chaos Lord.

How do I kill Him? [28]

The Room details

S - Start room. Contains the Chaos Lord. Beneath the Crystal behind the door is a SKULL key. [56]

What do I do once the Chaos Lord is defeated? [109]

This page is intentionally left blank

Fagranc - Level 7

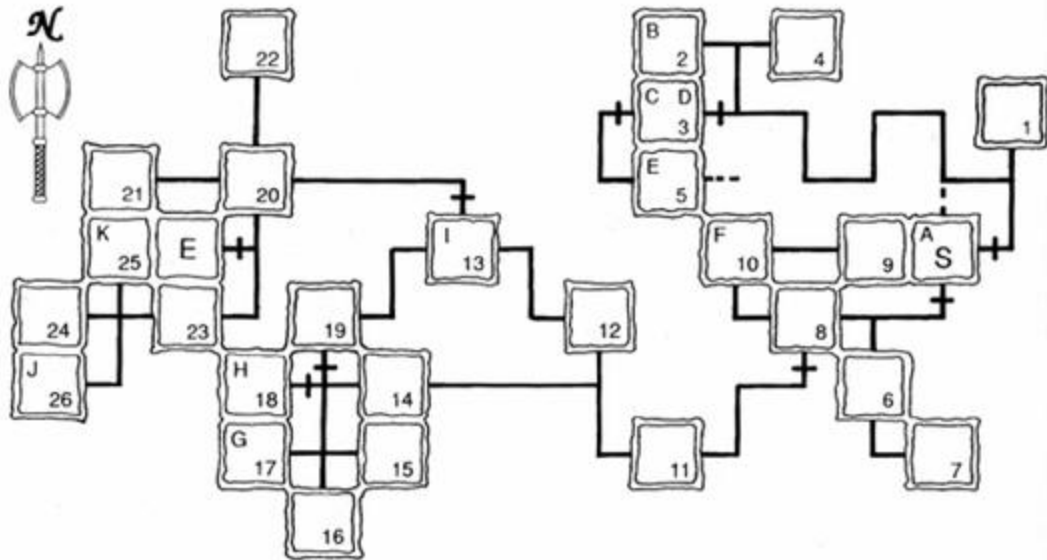

KEY	Located at	Opens
(A) UNKEY	Start Room	The Unshrine
(B) CRYSTAL	Room 2	W door, outside room 3
(C) GOLD	Room 3	Door inside room 3
(D) IRON	Room 3	W door, room 3
(E) CRYSTAL	Room 5	E door, room 3
(F) BRONZE	Room 10	S door, room 8
(G) GOLD	Room 17	W door, outside room 18
(H) SILVER	Room 18	N door, outside room 19
(I) ORNATE	Room 13	N door, room 13
(J) IRON	Room 26	Door inside room 25
(K) DIAMOND	Room 25	W door, outside Exit room

Fagranc - Level 7 (of 8)

This is the last time you will have to return to Fagranc, as there are only eight levels.

You will need to go down into Level 8 via two different exit rooms on this level.

The Room details

S - The start room. A sign reads "In Skalet Rha..."

3 - There are three sets of double floor spikes here. A blocked chest stands in the NW corner. Some spikes block progress into this room. A square green floor switch lies in the NE corner with a key lying on it. A square blue floor switch lies in front of the NW chest which is behind a door. A pillar lever stands in the SE corner and three consecutive doors stand in the middle of the room. [16]

5 - The stairs here lead down to Level 8.

13 - There are E and W halves to this room. The E half has a N facing door and a pillar lever. A door in the W half has beyond it a long chest. [53]

25 - There is a locked door in here. [125]

E - This is the exit room down to Level 8.

Fagranc - Level 8 (of 8)

The last level of Fagranc is effectively in two halves. Each side of the level is reached via the Exit room and room 5 in Level 7.

This level also contains the final power gem - the Chaos Crystal.

The Room details

S - The start room.

21 - A pillar lever stands in the middle of the room, flanked by chests on the E and W sides. The lever is blocked by some floor spikes. The N exit is blocked by spikes and the E door is locked. [34]

22 - There are fourteen teleport pads lying in the W side of the room. A long chest stands on the W edge of the pads. A round yellow floor switch has to be stepped on to reach the teleport pads. Three skull tiles lie nearby. The NE door has a paralyze rune on the floor next to it. A pillar with sign stands in the S-SW passage, beyond a door. It says "Venture forward and offer your rune". A rune lies beyond this pillar in the SW corner. [47]

26 - There is a pillar lever in here. [114]

27 - This room contains a blue button. The sign reads "Find lever and pull it again" [38]

28 - This room contains a green button and a sign which says "Find lever and pull it again". [54]

30 - You need to reach the long chest in this room. There is plenty of water in this room as well as a trench of fire, a teleport pad, a couple of pillars, a floor grate a teleport rune and two skull tiles on the floor. [77]

31 - The Chaos Crystal is in this room!

What to do once you've completed Fagranc? [15]

The King - Level 1

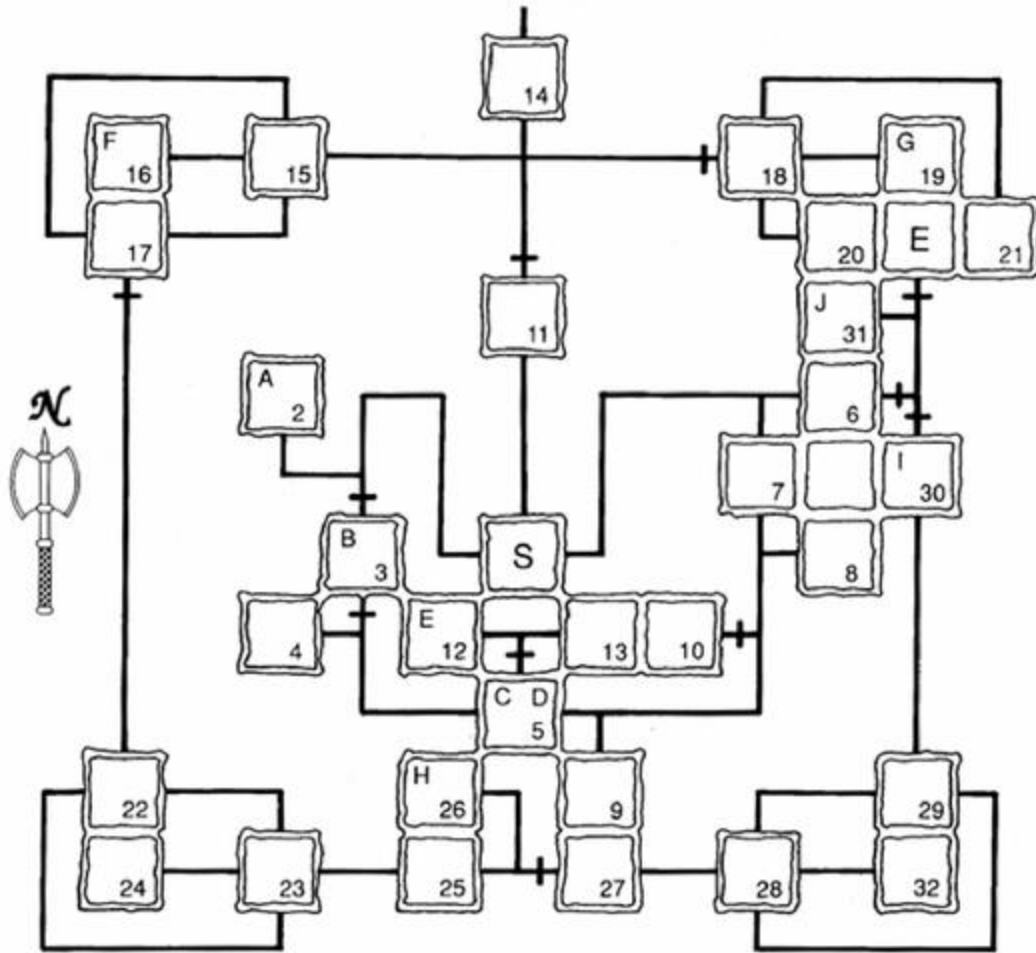

KEY	Located at	Opens
(A) DIAMOND	Room 2	S door, outside room 3
(B) AZURE	Room 3	S door, room 3
(C) CRYSTAL	Room 5	N door, room 5
(D) EMERALD	Room 5	W door, outside room 10
(E) BRONZE	Room 12	N door, room 11
(F) SILVER	Room 16	E door, outside room 18
(G) IRON	Room 18	S door, room 17
(H) RUBY	Room 26	E door, outside room 27
(I) IRON	Room 30	N door, room 30
(J) GOLD	Room 31	N door, outside Exit room
(K) DARK	Exit room	W door, outside room 6

The King - Level 1 (of 3)

You must fight through three levels and find then kill the evil leader behind the invasion. This is the toughest dungeon by far!

Want to know more about this final dungeon? [86]

The Room details

S - This is the start room. [121]

3 - Three square yellow floor switches are placed around the edge of this room. A couple of chests stand in here and there are lots of markings on the floor. A pillar with a sign stands in the NW area which reads "The magic distillery". Characters are zapped around the room very fast when they step within. [102]

5 - This room is split three ways: N, W and E.

10 - A red pillar button is here. [78]

14 - The north door won't budge in this room. A sign reads "The Castle - Please leave all weapons on the rack". [115]

27 - There are four square green floor switches in here leading to the E exit. [83]

30 - This room has a number of watery areas and three skull tiles in a line. The E half is bridged by a floor switch, and a pillar button and chest stand isolated in the NW corner. The E side has one solitary skull tile and a pair of double floor spikes. How do you reach the NE exit? [25]

31 - A regeneration room. The sign reads "Reforge thy bones".

The King - Level 2

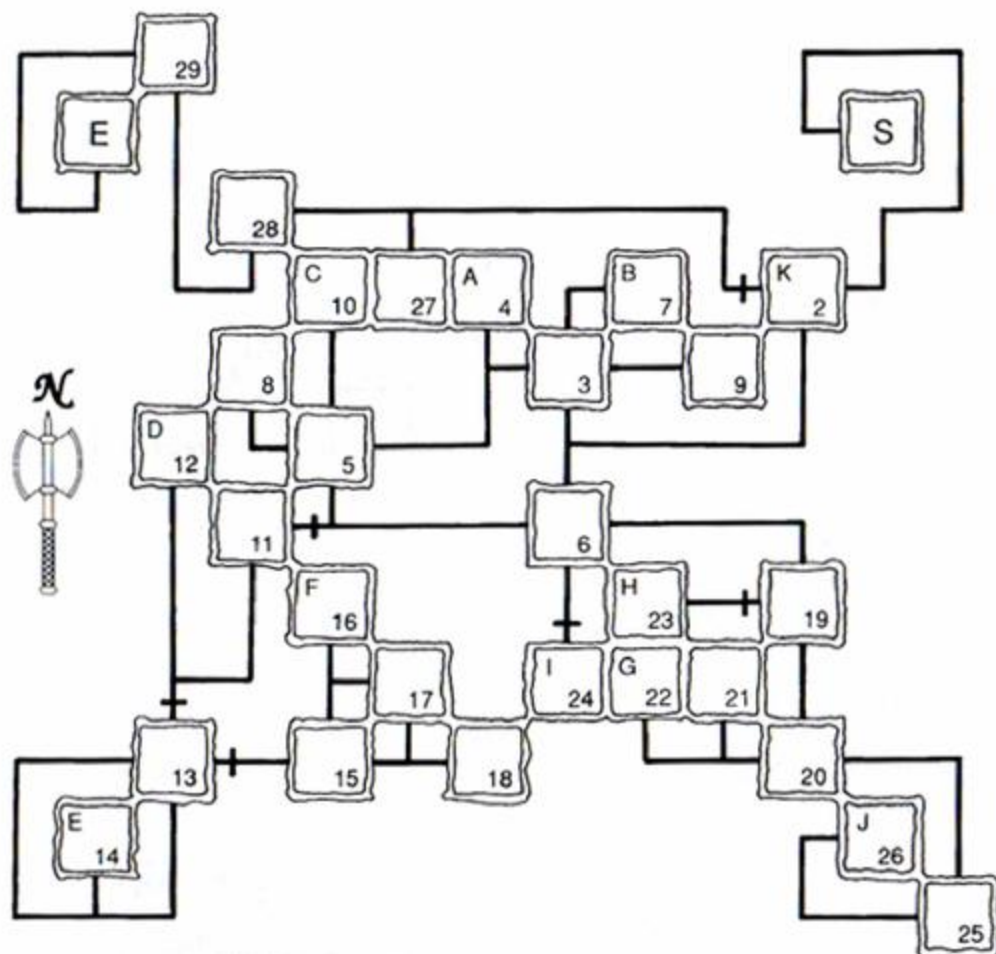

KEY	Located at	Opens
(A) CRYSTAL	Room 4	Door inside room 2
(B) AZURE	Room 7	Door inside room 2
(C) BRONZE	Room 10	W door, outside room 11
(D) GOLD	Room 12	S door, outside room 13
(E) BRONZE	Room 14	E door, room 13
(F) EMERALD	Room 16	Door inside room 2
(G) IRON	Room 22	W door, room 19
(H) DIAMOND	Room 23	S door, outside room 24
(I) RUBY	Room 24	Door inside room 2
(J) ORNATE	Room 26	Door inside room 4
(K) TOPAZ	Room 2	W door, room 2

The King - Level 2 (of 3)

What is going on in this level? [45]

The Room details

S - The start room.

2 - Four square floor switches lie behind four doors. Each one is locked. The W door is also locked. [84]

4 - A pillar lever stands behind a door in here. [97]

28 - The sign reads "His Royal Majesty awaits you in his chambers".

E - Exit room to Level 3 - the final dungeon!

The King - Level 3

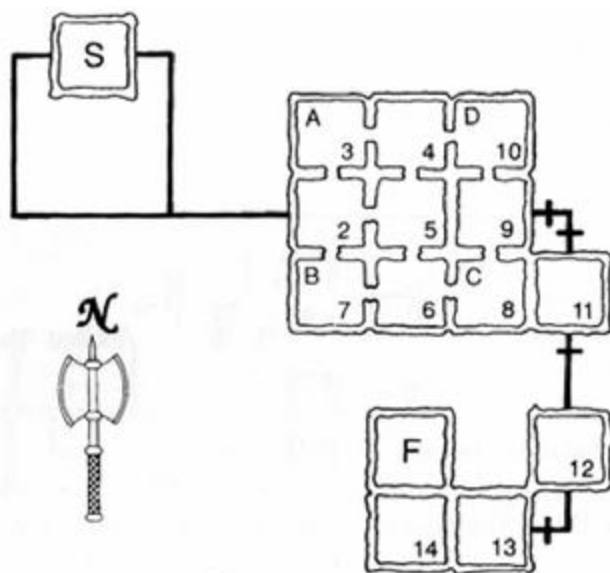

KEY	Located at	Opens
(A) GOLD	Room 3	E door, room 9
(B) GOLD	Room 7	S door, outside room 11
(C) GOLD	Room 8	S door, room 11
(D) GOLD	Room 10	W door, outside room 13
(E) CRYSTAL	Room 13	W door, room 13

The King - Level 3 (of 3)

This is the final level. Your destiny awaits. Have you what it takes to become Legendary? Will you free the land of Trazere of the evil invasion for ever?

The Room details

What should I prepare to face in the final dungeon? [116]

S - The start room.

12 - A sign here says "Mighty though you are, you will not defeat me".

13 - Another sign encouragingly reads "Take this key and prepare to die"!

14 - The King's chamber! [70]

F - The final room. [58]

Help and Advice

Character Selection

To have any chance at all of battling their way through to the end, the player must start as he (or she) means to go on. The selection of character's statistics at the beginning of the game is an important decision that shouldn't be taken lightly.

Try to remember that each character class has a special ability that is unique to that character. Each ability needs to be strong in certain ability scores if they are to fully utilise it. The default party of four presented to the player at the start is okay for a beginner to use whilst familiarising themselves with the game, but it is a good idea to amend the scores when they are ready to begin the quest in earnest.

The scores are adjusted by adding the influences of the four elements - earth, fire, air and water. Their effect on the scores is described in the game manual. It seems sensible that all of the characters should have strong scores in all of the abilities, but unfortunately life in Trazere is far from perfect or fair. If you are strong in one score, you will be weak in another. You cannot achieve the highest scores in everything, so you must learn to be selective. Focus on those scores that are needed by the special ability that character possesses.

e.g The Berserker should be the strongest natural fighter in the group, so his scores should reflect this. Strength (Str) and Armour Class (AC) are the most obvious scores to improve. The one that needs least attention is intelligence (Int).

As you will know from the manual, some of the elements allow you to increase one good fighting score whilst it consequently decreases another important combat score as a result. Therefore, only one or two of the ability scores should be concentrated on as being the important ones to improve.

The Berserker - Str, AC
The Troubadour - Str, Int
The Assassin - Spd, Dex
The Runemaster - Int, Spd

You could use this section to set your own difficulty level for the game. This can be achieved in a number of ways, e.g by defining a weak but intelligent Berserker or a slow and stupid Runemaster who fights well.

GENERAL STRATEGIES

Following are some good tips for keeping alive and maintaining the balance of good versus evil in Trazere.

Monster bashing

You might have noticed that there can be rather a lot of monsters attacking your party at the same time, and the odds look heavily stacked against you when a horde of monsters decide to perform some synchronised adventurer bashing!

Entering a fight should become a series of quick commands that are repeated over and over again. It will become an almost automatic response by the player once they have done it often enough.

It is also recommended that you "power up" the party before entering a new room. Select each character in turn and check if they are protected by Antimage or Regeneration. If anyone is not protected then cast the relevant spell on them using either a scroll, ring, potion or the Runemaster (assuming you have the ability to do so). Speed and Teleport are also very useful spells to cast on characters at this time. It is also a good idea to ensure that everyone has an object equipped that can be used to his or her advantage during a fight before entering a new room.

Once in combat click on the Rally/Party attack icon to get everyone fighting. Immediately select the Berserker and put him into 'Berserker Rage'. (If the Troubadour has a battle horn then use it to berserk him too.)

Immediately select the Assassin and make him 'Hide in Shadows'. (Teleport items such as the cloud ring or, even better, the Angel helm (Teleport Speed) are very useful to the Assassin as they enable him to get behind the monsters right at the start of the combat, increasing his chances of doing a critical back attack.)

Ensure that the Troubadour is playing a 'Bardish Melody' that is advantageous to the situation in hand (e.g Warriors Awakening' is going to be of more use in a fight than 'Adieu Sweet Dullard' - although the Runemaster might disagree with you on that one!). In the early stages of the game "March of the Bold Ones" should be kept up at all times as the extra hit points given by this weak regeneration song can be the difference between life and death in combat.

Get the Runemaster ready to cast any relevant spells.

Remember that the party must act as a team during a fight. They will perform a number of actions under their own initiative but they will need prompting from time to time. Don't just sit back and watch them join in the melee. Be prepared to get them to help out a fellow adventurer who is in trouble. The Rally option can be used to get the remaining adventurers to help out an over-powered colleague, or you can equip the relevant character with an object that will help him out on his own.

You can equip a new object in the middle of a fight. Select the Inventory screen and (thankfully) the action in the dungeon is automatically paused. You can now select a scroll or potion (or any other item if you know it will be useful) and equip it, ready for use. e.g Serpent potions are always handy to have, so that your hit points can be healed (the amount that they are healed is dependent on the strength of the potion - the brighter the colour of the potion the stronger it will be. Those bought from the Temple always heal a character to full hit points as will the Serpent Shield found later in the game).

You can pass around magical items that can be used more than once such as Amber Rings (Antimage) and Sun Rings (Regeneration) if the characters are clobbered with Dispel from a magic-using monster or if you are carrying a Dragon Helm (Surround Damage) and the wearer is not the one in the thick of the battle. Once one character has used one of the above rings, pass it on to the next character and so on. The effect of the ring remains even when they no longer wear or possess the ring. Antimage on Regeneration can be removed by dispel so you should keep an eye in the bottom right hand side of the message window in the main dungeon display to check that the effect rune is still active.

All items do eventually expire, but the number of casts you can get from them does vary.

Remember that when you are passing rings or helms around in this fashion once you have passed the item on to the next character, the previous adventurer must re-equip any armour or other items that were automatically deselected when the magical item was used.

On occasions the Assassin might need to be prompted to move behind a monster to do more damage or you might need to get help to a character who is surrounded by monsters by selecting Rally when they are the Leader.

It is often wise not to allow your Runemaster to enter the melee by switching off his weapon after rallying or (more simply) by having deselected his staff from the Inventory screen and having him equipped with a couple of wands or a wand and a scroll or potion. You can then keep him out of the fight by moving him to a safer area in the room (if one exists) or by drinking a Moon Potion and leaving him invisible.

During melee the most dangerous monsters by far are the magic-using ones. They should be dealt with as quickly and as efficiently as possible, a task often best assigned to the Runemaster. A good tactic could be to Teleport next to the offending mage and hit him with a Surround Damage (or Missile Dispel Disrupt Damage if you're feeling particularly paranoid!).

Another amusing tactic can be to have the spell Missile Dispel Paralyze ready and create a living cage of monsters as a safe haven for your Runemaster to Teleport into and out of while the rest of the party beat seven bells out the remaining monsters.

'Nuke' spells (Surround effect Missile effect Surround effect Missile effect) can be devastating during a fight. Try experimenting with Thrall, Paralyze or Damage effects, or even Vivify, but make sure everyone in the party is protected with antimage and avoid 'nuking' with Disrupt!

Running away

There might be times when you find that you need to flee to a safer room or corridor to fight the hordes. Believe it or not, the less entrances/exits there are then the safer you will be from ambush (as there are fewer entrances for monsters to ambush you through).

Once a fight is over

The highest priority is to Heal everyone in the party. This can be done by magical spells, scrolls, potions or by other magical items.

Next, any continuous spell effects that they had (Antimage and Regeneration) should be restored if they have been dispelled during the fight.

You should then pick up any bags of gold or other items that have been deposited by the vanquished monsters. It doesn't really matter who is assigned this task as the gold can be shared out equally once the party is out of the dungeon environment.

You might wish to switch the Troubadour's melody to the healing tune 'March of the Bold ones' (if he isn't already playing it).

You should really do these in the prescribed order as there is a chance you might be ambushed again shortly after a previous fight and the party should be back to good health as soon as possible. Gold will always be there if you come back to it later (even if you leave a dungeon).

Dead Adventurers

Don't leave the bones of fallen comrades lying around. Not only is it disrespectful but you may find yourself wandering around scouring the dungeon for them later.

There are a number of ways of bringing characters back from the dead. The only option available initially is to take the bones back to a Holy Temple for resurrection. The nearest Holy Temple to Treihadwyl is in Martindale (a village just North-West of the Castle).

There are rooms on the first level of Treihadwyl and again on the first level of Fagranc with Vivify chambers which can also be used once they have been located ("Reforge thy Bones"). These chambers cast the spell Continuous Vivify Heal which can of course be cast by the Runemaster to create a Vivify chamber whenever needed, even during combat! Magical items which use the Vivify effect can also be used:

Serpent wands (only used by the Runemaster)
Chaos Helms (used by Berserkers, Assassins and Troubadours)
Forward Vivify scrolls (used by any character)
Serpent staff (Runemaster only)

Luck

A small amount of Luck points are restored to a character when they are brought back to the land of the living. This amount depends on the intelligence of the character casting the Vivify (a high intelligence will generate more luck). For best effect, get the Troubadour to sing 'Adieu Sweet Dullard' (see Appendix G), equip the Runemaster with the Ancient staff and cast Surround Vivify on the bones of the expired character. The bardish melody 'Adieu Sweet Dullard' and the Ancient staff both boost intelligence.

Resurrection at a Holy Temple bestows no luck on a character. It is best to get them more luck by praying or by the use of Craven Images or Holy relics, which can be bought from some Artificers. The maximum amount of luck allowed is 16 if you pray, but you can go up to 32 if you use 'Images or 'Relics.

There is one final option to dealing with dead adventurers. Restore a save position from before they died and try to avoid it next time!

Useful Objects

The game manual stresses their importance strongly enough, but it is worth mentioning again here. The objects that you can buy or find in Trazere can save your party from the jaws of defeat and aid them to victory. Their abilities cannot be ignored.

A few useful objects are listed here to give you some idea as to their use. All of these items can be used by anyone. Other items have restrictions according to the character class of the adventurer. These are detailed in an extensive list in the Appendix.

All rings have a random number of uses before they expire. Some have lasting effects where others only have immediate effects. All potions and scrolls can be used once and once only. Some have immediate effects, whilst others have lasting effects.

(i) Serpent Rings - for restoring hit points by Healing. (Immediate effect).

(ii) Serpent potions - for restoring hit points by Healing. (One use only, immediate effect).

(iii) Amber rings - Antimage spell. Will protect you from harmful magical attack. (Lasting effect until dispelled).

(iv) Sun rings - Regeneration spell. This rapidly restores lost hit points. (Lasting effect until dispelled).

(v) Cloud rings - give user Teleport. (Immediate effect).

(vi) Dragon potion - gives user Regeneration Speed Antimage. (Lasting effect).

These items can be useful to particular characters:

Berserker:	Golden helm (Forward Damage) Blood helm (Surround Damage) Serpent Shield (Full Heal)
Troubadour:	Battle horn (Berserk) Golden helm (Forward Damage) Dragon Shield (Surround Damage)
Assassin:	Angel helm (Teleport Speed) Dragon Ring (Surround Damage)
Runemaster:	Amber wand (Missile Damage) Dragon wand (Missile Damage Surround Damage) Sun wand (Missile Damage Surround Missile Damage) Moon potion (invisibility)

Any item that does additional damage in combat is useful to **Berserkers**. They never normally need to be artificially boosted as they are already psychotic killing machines!

If the **Troubadour** has a non-magical instrument (mandolin, horn or lyre) and he wishes to use a magic helm, ring or shield, he can equip an ordinary instrument after he has used the battle horn thus freeing the magic plinth. Don't forget to re-equip the battle horn after the combat is over or else he won't be able to berserk in the next fight.

WARNING! Certain items contain very powerful magic that can kill everything in their area of effect (even characters protected by Antimage). Beware of the Arcane Mandolin, Dragon Helm and Dragon Staff and only use these items as an absolute last resort!

Banners

Apart from battling your way through all twenty three levels and defeating the warped plans of Chaos, you also need to keep an eye on the events that happen on the land Trazere. If unopposed, the evil armies (represented by red banners) will overrun the land in little under six to eight weeks.

Take on the easier banners to begin with, using the same tactics as described in the monster bashing section. Just remember not to be tempted to click on Elliott to pause the game by bringing up a game map, as he serves a different function during banner encounters and selecting him will make you retreat from the fight and lose your horses to the enemy! Clicking on Elliott when you have beaten the enemy will take you back to the land map safely. In any event, you will find it very difficult to take on any banners until your party has an average experience level of 3 or more.

You can get a fair amount of money and experience points from a successful banner encounter. Each enemy banner is led by a hero monster and his arch-mage. Both of these have magical protection and are very tough so try to dispose of them as quickly as possible (casting Dispel at them is often a good start). When defeated these two often drop powerful objects not otherwise yet available. Banner hunting can also be a good way of slowing the spread of evil.

Keeps

Keeps don't need donations of gold until mid to late Fevery or early Mage. Whenever you come out of a dungeon, have a quick look at the status of each Keep's defences. If it is 'lightly' or 'barely' defended, then it needs a hefty cash injection. You could just kill off all of the enemy banners currently on the map instead. If you have balanced things correctly, you won't be forced to make a choice between donating gold or buying other things. Money can be plentiful if you collect it sensibly and spend it wisely.

MAKING MONEY

The most obvious way of making money is to destroy monsters and collect any bags of gold that they leave behind. It doesn't matter who gathers it, as it can be shared out again outside of the dungeon environment via the share gold and pool gold icons.

You can also make money by selling off excess objects that you no longer need or have an abundance of. For example, you can collect quite a few different swords that you might not need. These can be sold to a Blacksmith when you next leave the dungeon.

You might find yourself carrying too many items. Just leave the excess items in a convenient location (the start of a dungeon level is a sensible place) so you can pick these up again later and sell them.

A little known feature of 'Legend' is the ability of the party to forget about the quests for a time and to a bit of trading. Items vary in price from place to place, so it is possible to buy cheap and sell expensive. The price guide in the appendix section will help you gauge whether you're getting a good deal or not. Shops which don't stock a particular item will always purchase it for a better price.

Your profits may not seem worth the effort of travelling the length and breadth of the Kingdom in the early stages of the game, but when you start trading in more exotic artefacts your gold will increase exponentially.

Management of money is very important during the game. You will have to allow for the expense of training up to a new level (which increases by 500 gold for each new level reached), buying runes, buying ingredients (without which you wouldn't be able to mix any more spells!), and donating to needy keeps. Which one you choose is down to your appraisal of the situation at hand. Making the wrong choice at the wrong time can be very inconvenient (as nobody gives credit).

In the final dungeon (The King) there is no need to collect the bags of gold, as you will not get out again to spend it! Force of habit might make it difficult though for you to leave all that gold just lying about and making the place look untidy.

The only monsters in the game who definitely won't leave behind gold for you to collect are dragons, who vanish in a puff of smoke and leave behind bags of ugly teeth instead (the Dragon Tooth ingredient for spell mixing).

Making Mystical Weapons

The rune Make Weapon will create a Mystic Weapon suitable for each character's class. These weapons can be more effective than the ones your party already possess. They are most useful on Chaos creatures, who can only be harmed with Mystic Weapons and spells (like the Chaos Lord in the Unshrine, or the creatures who roam the lowest level of Fagranc).

There is a down side to Mystic weapons. They can be completely destroyed by a Dispel but the character will automatically equip another normal weapon if they are carrying one.

If you cast Make Weapon on a character and their weapon does not change to a mystic one, then their inventory must already be full. The rune simply un-equips the normal weapon and adds an equipped mystic weapon to the inventory. The normal weapon is still in the inventory but is no longer in use. If it cannot add the mystic weapon due to lack of room, then the spell will fail, but only on that character. If you want the character to have a Mystic Weapon then you must free a slot for them in their inventory and cast the spell again.

MINI - TIPS

On entering a dungeon, immediately get the Runemaster to protect the party with Antimage and Regeneration if he can and get the Troubadour to play a melody. The Runemaster should have pre-prepared his spells ready for use before entering the dungeon.

You don't have to OPEN then LOOK then TAKE to take an object. Simply selecting TAKE and selecting a container will cause the character to walk up to it, open it, and take anything that he finds. You are told if nothing is there.

Don't buy any ingredients that you don't need with the runes that you currently possess. You will need the money for more relevant things. It's worth shopping around Apothecaries as prices can vary by up to 3 gold on each individual ingredient and hundreds of gold can be lost by a poor choice.

Don't allocate all ten spell slots to spells. You will come across puzzles that need certain spells that you are unlikely to keep afterwards. If you have filled up the slots you will have to junk valuable ingredients that cannot be recovered when it comes to making these temporary spells. Leave one or two blank and you should be okay.

Outside the 3D dungeon environment the Runemaster doesn't need a bowl to mix spells. If cash has been so short that you have had to sell his one and only bowl, just do your spell mixing while out of the 3D dungeons (done by selecting the Runemaster as leader and pressing "S" on the keyboard or clicking on the Runemaster's face icon). Any artificer can sell you a new bowl.

Level Solutions

1. This level additionally requires SURROUND.
2. The N door is opened by stepping on the round green floor switch by the door, which is only accessed by building a bridge from the E side of the room.
3. Solve room 14 to create access to the floor switch. Stepping on the floor switch removes one of the pillars, revealing a chest which contains the key for the Exit room.
4. This room is only reached once the next dungeon level has been completed.
5. The door is locked with a RUBY key.
6. The red button creates a corridor at (***)).
7. Once again you won't be able to enter the next level beyond the start room, where you will find the Unkey. (This gives you a rather obvious clue as to where you should be going next!) Now visit a Tavern to be told that "Legend has it that only a Mystic weapon has the power to kill Tetrahagael".
8. On completion of this level, go back through the previous level and leave the dungeon completely. You should now leave Treihadwyl and visit the King who lives nearby. The Guard will allow you entry, and the King will give you his quest to rid Fagranc of evil. He will give you an ORNATE key in exchange for the permit and 1,000 gold to the party leader. Before you set off on the long journey to the city of Fagranc your first priority should be to buy some faster horses so that the party can move quicker across the map. Visit the nearest Keep which is Hightower, and pay 100 gold for four Destriers. You will also consider buying some new runes from the Ancient and 'tooling up' at the Blacksmith. A 'must buy' is a Battle Horn for the Troubadour, available from most Artificers.
9. The chest is only reached once the button in room 15 has been pressed. The chest contains the key needed to open the door that blocks the exit stairway in this room.
10. The lever here turns off the spikes in room 13.
11. Stand your characters on all of the spare pads in the S side of the room. One pad will rapidly transport a character past each of the N side levers and back again. When a character stands on this particular pad, immediately get another character to stand on it so that the transported character is forced to stop in front of one of the N pillar levers as he has nowhere else left to go. Timing is critical in here. Then get the others to stand on the pad to be teleported to other pads in front of the levers. (The best approach is to get the second character to begin moving to the teleporting pad from further away before the first one (who should be next to the pad) steps onto it.)
12. Both doors are opened with ORNATE keys. When pushed, the buttons open the two doors S from this room in the corridor outside.
13. To remove the new pillar you need to pull a lever in another room to fix the lever in this room. Once fixed, the lever here will remove the pillar and allow you to press the button and open the S door.

-
14. Turn to the room solutions section at the back of this manual and look at solution [B] for the answer to this puzzle room.
 15. Once you have the crystal you must make your way out and deliver it to the fourth and final Keep. Now you must visit a Tavern. You will be told who is responsible for the evil invasion! Now it is time for the final dungeon...
 16. Characters are immediately teleported to different areas within the room. Only one is placed in front of the spikes that block progress into the room. Get him to pull the SE lever and the NE spikes will be removed. Take the potion and the key. The NW door is opened with the key. The square green switch removes the floor spikes from the W door exit. The key within the NW chest opens the W exit door. The square blue switch creates a pathway on the N side. The E door locks behind you when you leave via the W exit. This door requires a CRYSTAL key.
 17. The door within is opened by a SILVER key.
 18. Both doors are opened with ORNATE keys.
 19. Turn to the room solutions section at the back of this manual and look at solution [C] for the answer to this puzzle room.
 20. The first three characters are teleported to the raised W platform, leaving the last character to fight Kilijan himself! Kilijan is immune to DISRUPT and to PARALYZE and is initially protected with ANTIMAGE. You should hit him with a DISPEL and lots of DAMAGE spells to kill him off. The battle might take a while to complete and you may even not survive so save the game before entering the room. The Ancient's Staff is in the drawer and there are two keys elsewhere in this room. The other characters can free themselves and join in the fight by operating the levers and floor switches by the raised platforms. If the Runemaster is one of the trapped characters, he can shoot spells across the chasm.
 21. The door here is unlocked with an UNKEY from Fagranc - level 7.
 22. Stand the Berserker on the nearest pad to the entrance tiles. Now stand the Troubadour on the other nearest pad (orange). He will be zapped behind the spikes. Stand the Assassin on the same pad and he will be zapped to in front of spikes. The NW lever adds a skull tile to the middle of the room. Stand the Runemaster on same orange pad and he will be zapped around the teleport pads in the S/SW area of room, along with the Assassin. Select 'cast spell' and the Runemaster will stand still with his arms in the air, breaking the perpetual teleport loop he was stuck in. Get him to step off the pad he is on and then step back onto it. He should be teleported to another pad and stop. Get the Assassin to step off his pad and step back on. He too will be moved. Continue this until the Runemaster is placed on the skull tile in the middle of the room. Stepping W from here should create more skull tiles allowing him access to the W door.
 23. If any of the party have died, drop their bones on the circle next to the pillar with the button. Now press the button and step away. A few seconds later and the dead adventurer will be back to life. You must realise, of course, that the last thing the character remembers is being killed so don't be too surprised if they decide to flee towards the nearest exit!
 24. To enter you need to invoke the power of the stones, by naming the ZENDITES (as told to you by a Barkeep). You can answer with DRUIDS for some helpful info

-
- regarding where the Unshrine will appear next. This need only be done when you have to enter the Unshrine, which will be later on in the game.
25. Turn to the room solutions section at the back of this manual and look at solution [H] for the answer to this puzzle room.
 26. You will emerge at the end with a Moon Crystal (Blue) which should be given to a Keep (e.g Delmortis). A contribution should also be made. Visit a Tavern to be told that "Legend has it that the Chaos Lord resides in Skalet Rha".
 27. This level requires DISPEL.
 28. As soon as you arrive the party will be split up into the four corners of the room by a teleport pad directly in front of the entrance door. The Chaos Lord will move in on the last to enter the level. You must attack from all sides. He is only harmed with Mystic Weapons. DISPEL will remove any of his magical protection but DAMAGE only inflicts about one quarter of the usual damage on him. He is immune to DISRUPT and to PARALYZE. Bring back dead characters to life if necessary. Tetrahagael takes an enormous amount of hit point damage before he will die. Try and trap him on all four sides. Ensure that the Runemaster is not directly facing the front of Tetrahagael and that the Assassin is positioned behind him. Keep the character that the Chaos Lord attacks alive by casting HEAL spells on him.
 29. Pull the lever once to rotate the pillar and give access to the red button. Push the red button once. Pull the lever a second time and the pillar will vanish, to reveal a key which you should pick up.
 30. The door within is locked with a CRYSTAL key.
 31. The skull tile on the floor removes the S double floor spikes as does the blue button if no character is able to reach the skull tile. This would be used on returning to the room via the S exit. The chest is almost a red herring. When a character stands next to the chest the E door is locked and requires an ornate key, one of which is in the chest. You never need to open the chest so, unless you want to get temporarily locked in, don't stand next to it.
 32. The lever creates a new path at (*).
 33. Use a cloud ring, a cloud potion, or a teleport spell to reach the chest.
 34. Pulling the lever in here after pushing the button in room 27 creates access to room 28.
 35. Stand one character on each of the three teleport circles on the E side of the room. The character who stood on the middle one will be being zapped back and forth between the middle circle and the isolated one in the SW corner. Stand the fourth character on the middle circle - keep trying if he is unable to step onto it. The "zapping" character should now teleport over to the lever. The lever removes the floor spikes and the floor switch opens the door.
 36. You need to paralyze a monster on one of the skull tiles on the floor, then stand three of the party on the tiles, leaving the last to safely stand on the switch and approach the chest. Open the chest and get what is inside before the monster wakes up! If there are no monsters in the room then you will have to go and find one and lead it back to this room.

-
37. The SE door is opened with a TOPAZ key. There is a common sense solution. The three buttons create new paths when pushed. Get two characters on the teleport pads and one will be zapped to the lever in the NW corner which removes the spikes from in front of the chest.
 38. Push the blue button then return to room 21.
 39. This particular level requires PARALYZE or an item of paralysis.
 40. The door within needs a GOLD key.
 41. The blue switch creates a hole when stepped on to prevent progress. The red switch fills the hole and allows you to continue. The lever creates a path in room 32 to reach the S side in that room.
 42. Ensure everyone is healthy and that you can bring dead members back to life. Also ensure everyone is armed with a Mystic weapon and that you can create more if necessary. You are now going to try and kill the Chaos Lord himself!
 43. This room is rotated by levers, allowing access to other parts of the map by changing the available exits. Initially the exits the party comes across are S and E.
 44. Get your healthiest character to open the chest so that he can withstand the blast. If they are protected by ANTIMAGE then they will have nothing to fear.
 45. This entire level is one large puzzle, which involves room 2 and the operation of certain floor switches to create various corridors. The room numbers affected by the square floor switches behind the doors in room 2 are as follows: Green - Room 3, Red - Room 5, Orange - Room 6, Blue - Room 20. You will never see the map in its complete form in the game, as it is not possible to have all of the exits from the rooms available at the same time. See also [84].
 46. There is a reliable way of predicting where it will be next. Visit MOONHENGE and type DRUIDS when you are asked to invoke the power of the stones. You will be told where the Unshrine is due to appear next Beamday (either in the North, South, East or West). Move to that region of the map and wait for its arrival. Enter quickly once the Unshrine arrives as it will disappear as the sun rises.
 47. Stand the Runemaster on the teleport pad roundabout. Get him to cast a spell whilst he is in front of the chest and he will stop moving and raise his arms. If he is opposite the chest get him to take whatever is in there (including a key). To get him off the roundabout, do the same but do it when he is opposite the yellow switch, then simply step off. The key opens the door leading to the pillar sign. The Runemaster must stand in front of the sign and cast the spell 'Missile Forward Missile Paralyze' at it. Part of the spell will pass through the pillar and hit the SW rune and open the N door.
 48. The door is locked with an AZURE key from room 2. The left and right-hand pillars change the function of the middle pillar. The middle pillar either flips the inaccessible pillar in the NW or causes it to fire a Missile-Damage spell at the runes on the floor. You must hit each rune to remove the spikes and reach the button. When pressed, this removes the last set of spikes in room 8.
 49. The lever opens the door that won't budge in this room.

-
50. This is a clue to lead you to the Dark Tower. Visit a Tavern for further information. Do not go to the Tower before you've done what the barkeep suggests! Obviously, if you have done the Dark Tower then you can ignore the sign.
 51. The W or E approach to this room is a dead end until the room is rotated by levers. You should not rotate room 5 until you are sure you know a route back to where you wish to go next. Do not rotate the room until you have opened up the Ruby key path (starting in room 2 on level 1).
 52. You must first solve room 18 to be able to progress through this room.
 53. The N facing door in the E half is locked with an ORNATE key. The lever opens the door within the W half, which has beyond it a long chest with the key to the N exit inside. Visit the W half and kill one of your party (NOT Runemaster - Assassin or Troubadour ideally). Leave their bones in the W half and walk back to the E half. Pull the lever to open the W door and then get the Runemaster to VIVIFY the dead bones back to life, so that the character can open the chest in the NW corner and get the key.
 54. Push the green button and return to room 21.
 55. Room 4 has four exits but the party can only pass through it in right angles. It is rotated clockwise by the levers so pulling a lever once will change the available exit to the opposite compass direction. (Eg: If the party were to pass through room 4 in its original state, they would travel from S to E. If they then pulled the lever in room 10 and moved through room 4 again, their route would be E to N. The lever in room 13 would allow them to travel N to W and so on.) Pulling a lever a second time reverses the process (N to W becomes N to E).
 56. Once killed, the Chaos Lord drops an UNKEY which is used to open the S door which has behind it the Dragon Crystal (Red).
 57. The door within this room requires a BRONZE key.
 58. As you approach the sign on the pillar to the North, the final message will be displayed. You don't really think we'd let you know what it says do you? Only those of brave heart, strong steel and powerful magic will be able to see the end!
 59. The chest is reached by pulling the lever on the W side of the room. The key to the door within this room is in the NW chest. The door gives access to a green button which creates the bridge to the N door in room 15.
 60. The internal door is locked with a SILVER key.
 61. This level requires TELEPORT or some item of teleportation.
 62. ANTIMAGE is enough protection.
 63. It is opened with the AZURE key.
 64. The red button flips a floor tile between the paths in the N/W half of the room and the S/E half. After travelling to room 15 and collecting a key you will have to go to level 2 for a while. This will reset the room so when you come back up to level 1 remember to return to room 14 and press the button to open to path in the N/W half of the room as you will need to go that way later.

-
65. Unlock the outside door with an ORNATE key.
 66. The lever in this room rotates room 4 clockwise each time it is PUSHed.
 67. The Runemaster must cast a Healing and a Damage spell on the respective runes on the floor to open the W and E doors. Or, once you have found the Healing potion in the chest, drink it whilst standing on the Heal rune to open the E door. A Damage scroll or Golden Helm can be used on the Damage rune too.
 68. Each door is opened with a GOLD key. The chest behind the final door contains the key needed to open the E door outside room 7, giving access inside to the W side of room 7.
 69. The door within is opened with a GOLD key.
 70. Once you step in there is no way out! Your entire party will be paralyzed as it enters the room and there are hidden pads on the floor which will trigger off streams of damaging fireballs in all directions. King Necrix is guarded by two Chaos creatures similar to Tetrahagael which teleport into the room after the battle begins and they are just as difficult to defeat as the Chaos Lord himself was. The King and his minions are immune to DISRUPT and to PARALYZE and are initially protected with ANTIMAGE. Use DISPEL and Mystic Weapons on them. Concentrate on the King to begin with, casting as many DISPEL and DAMAGE spells on him as you can (ensure that the Runemaster is using a Moon Ring to become invisible). The King is tough but you should be able to defeat him eventually, provided you keep TELEPORTing around the room. The Runemaster will need to cast ANTIMAGE and REGENERATION spells on fellow adventurers all of the time, as well as casting MAKE WEAPON to re-equip them with Mystic Weapons when they are hit by DISPEL. The Runemaster is the single most important member during this epic battle. Keep him alive at all costs as the others can always be vivified back to life once the fight is over. The Assassin should be used to maximum effect behind the creatures armed with a Mystic Dagger. This battle might take a good few Minutes to win. Save in the previous room (13) before you go in.
 71. To enter you need to answer three riddles. You have the answers, which are as follows: Tetrahagael, Skalet Rha, Mystic. Also remember that if you wish to pop out of the Unshrine to stock up on ingredients etc., it might well vanish before you get back to it! Ensure you have enough before you enter.
 72. Turn to the room solutions section at the back of this manual and look at solution [A] for the answer to this puzzle room.
 73. Levels 5 and 6 are reachable but you cannot enter either yet beyond the start rooms for each. The skull key required for level 5 comes from Moonhenge. Leave Fagranc after you have briefly popped down into levels 5 and 6 and visit a Tavern. You will be told of the ratmen's discovery of a power gem in the sewers of Balenhalm.
 74. Search the alchemist's bench.
 75. To enter you must first type in KILJAN when asked to name him. Once inside you should fight off the monsters and then use the DARK key from Fagranc - Level 3 to continue through the door.

-
76. You should take the Crystal (Green) to Eb's Pass (a keep in the SE region) and give it to the people within. A contribution should be made here if they are 'lightly' or 'barely' defended.
 77. Turn to the room solutions section at the back of this manual and look at solution [G] for the answer to this puzzle room.
 78. The red button opens the N and W areas in room 5.
 79. The lever rotates room 5 to make the N/S exits a dead end and open the E/W paths instead.
 80. This lever rotates room 4 clockwise.
 81. You must cast a Damage spell at the rune on the floor to remove the pillar and gain access to the other half of room.
 82. Press the yellow button. This creates a short cut to the stairs which lead out of the tower.
 83. The floor switches have to be stood on to remove the spikes to reach E side exit. The first two can be walked to without hindrance but, as you try to reach the others, the spikes reappear. Methodically remove the spikes and progress eastward with a couple of characters until you reach the door on the E side.
 84. The W door needs a TOPAZ key which is placed in the middle of the room behind a pillar (and is therefore inaccessible until the pillar is removed). Turn to the room solutions section at the back of this manual and look at solution [I] for the answer to this puzzle room.
 85. The lever creates the remainder of the path connecting the N area to the E door in room 7.
 86. King Necrix has betrayed the land. Before you enter the King's domain, you should prepare your party since, once inside, there is no way out! You won't be able to pop out and buy more ingredients, objects etc. so your party must be well equipped before you enter. You will need all of the runes and about 500-600 of each ingredient. You can get away without having VIVIFY if you have a Serpent Wand and, preferably, also some way of bringing the Runemaster back to life if he should die (e.g Chaos Helm). You should try and stock up on all equipment you expect to use up and mix many of your most-used spells before shopping for ingredients. If you are close to any level breaks, think seriously about destroying a few banners for their booty and the experience points.
 87. Both switches must be stepped on. A minefield of invisible teleport squares cover the floor in this room. The switches create different 'safe' routes across the room. The teleport tiles send you back to the S door in the room if you step on one. The chest has a permanent teleport square in front of it. The only way to open the chest is to do it from the side. The flashy method is to stand a character on the tile N of the chest and stand someone else directly E of them. Paralyse this second character then take from the chest with the first character. They will try to move to the front of the chest but will find their route blocked and so will be forced to open it from the side, thus avoiding the troublesome teleport tile. A simpler method is to stand N of the chest facing it and TAKE at the character's own feet. This action will always cause a

-
- character to search his own location first and then the location directly in front (in this case the chest).
88. The other door needs a MOON key.
 89. The door within needs a CRYSTAL key.
 90. The door in front of pillar needs a TOPAZ key. This is another bad room to get caught in a fight. The lever opens a new corridor at (*).
 91. See [93].
 92. The Door is opened with a GOLD key. The lever creates half of the path to the N area in room 7 leading from the E door.
 93. The first reachable lever creates a blue tile in room 24 giving access to the unlocked door in that room. The lever behind that door creates a blue tile in room 25 giving access to the second unlocked door. There is also a SILVER key here. The lever behind the second door creates a blue tile allowing the party to reach the last door in room 24, which is unlocked with the SILVER key. The lever behind this door creates a floor tile which gives access to the SE corner of room 25.
 94. Stand a character on the S side teleport pad and cast a 'Missile Teleport' spell at the S side teleport rune to transport them to the other side/half of room. Do this three times until only the Runemaster is left. Now cast 'Continuous Teleport' on the S side teleport rune then walk to the teleport pad and step on it to be transported. On the other side cast a 'Missile Make Weapon' spell at the Make Weapon rune to create a round green floor switch in the middle of the area. Ensure that the other three characters stand on the skull tiles before the Runemaster steps onto button. If all skull tiles are not occupied then the floor switch will transport the Runemaster to them. On the return journey back through the room you need to cast 'Missile Teleport' at the rune to teleport each character across.
 95. Each door is unlocked with an ORNATE key. Each button turns off a different set of double floor spikes in room 3. Note that there are actually five ornate keys in the level, because in room 2 the E door locks behind you and requires an ORNATE key.
 96. Pressing the buttons in a certain combination creates and destroys different floor paths. Manoeuvre a character into the middle area of the room so that when the buttons are pushed, he can move to the newly opened area. Eventually they will reach the chest. Try alternating between pressing the red and green buttons, then get blue and yellow pressed when they are reachable).
 97. The door blocking the lever requires an ORNATE key. When pulled, the lever removes the pillar in the middle of room 2 giving access to the TOPAZ key. This will be the last thing to do in room 2 before you begin searching for the exit to the last level.
 98. The lever here removes the spikes in room 3.
 99. You should go down (i.e via the S exit), the party will be by the entrance to Level 3. You can take the Dark Key here but it won't open the W door. A sign reads "See you in the Dark Tower". You should go N back to level 2 then N again to room 29 in level 1 which links back round to the Start room. You have now accessed the "Great Stairs" which will allow you to get back down to level 3 with ease when you return later.

Follow the new path round and you will emerge back in the Start room of level 1. Leave Fagranc with the Dark key. Now Visit the nearest Tavern and talk to the Barkeep. He will either tell you to visit a Tavern in another area for the news or he will tell you there and then that the Ancient wishes to see you. Go to the Ancient and he will tell you about his evil cousin Kilijan and ask you to recover his staff from the Dark Tower.

100. E and S access is in the lower area, which is only accessible via the stair exits. NE and NW are above and can be reached easily.
101. You must stand one party member on the teleport pad on the floor. Another should pull the nearby lever which will send them over to the long chest. After taking the key from the chest, they should pull the lever on their side to send themselves back.
102. You must get three characters on the floor switches to turn off the teleporters. To do this, start with the Runemaster. Get him to raise his arms to cast a spell then quickly cast TELEPORT on himself and move to safe NW corner. Cast TELEPORT again on himself to appear in front of NE switch. Stand on it. More characters will begin to come out of this teleportation loop by the SE door. Cast TELEPORT on them and position them by the other switches. (You have to kill all of the monsters first). The Skull tile before the green chest is now safe to stand on and open the chest. Get to the SE area door to escape from this room. Crossing the room to get back is somewhat easier.
103. The Runemaster must have the CONTINUOUS and MAKE WEAPON runes. At this stage you should have most (if not all) of the runes.
104. Read Appendix E and decide whether you prefer to keep the staff or collect the reward then get out of the tower alive. If you prefer the reward, return to the Ancient. Now you must return to Fagranc - Level 3 with the Skull key from Kilijan's chamber.
105. The nearest lever will remove the spikes from the middle of the room, allowing the party across to the W side. This is a very simple room to solve, although one set of spikes can only be removed by visiting room 9 first and then returning here later. The BRONZE key for the W door is in the clock.
106. None, but you may regret not having ANTIMAGE or an item of antimage.
107. Turn to the room solutions section at the back of this manual and look at solution [D] for the answer to this puzzle room.
108. One door needs a BRONZE key, one won't budge and one is open.
109. Once out of the Unshrine, give the Crystal to a Keep which hasn't had one yet (e.g Boot Hill) and pay a contribution if necessary.
110. This room marks the top of the great stairs and is only reached once Fagranc - level 2 is completed.
111. The E lever moves a tile in the middle of the room. The W lever moves another tile which allows the party to leave the room via the S exit tiles. The blue floor switch adds another tile (which is required when you return later from the S exit and the floor tiles have reset).
112. When pulled, the lever fixes the lever in room 14.

-
113. The N door can only be reached once the green button in room 16 has been pressed. The button in this room is to recreate the bridge from the other side after you have been to Level 2 of the dungeon.
114. This lever removes the double floor spikes in front of the lever in room 21.
115. This message is just to add a bit of atmosphere. DON'T leave your party weaponless!
116. Somewhere in here awaits King Necrix III and you can guarantee that he won't be alone! A good tip here is to equip your Runemaster, Berserker and Troubadour with Moon Rings (which copy the Assassins special ability of 'Hide in Shadows'). If you only have a few, ensure that your Runemaster gets at least one. Don't use them up before you reach the King's chambers. The King is protected by two Chaos Lords, each one as difficult to dispose of as Tetrahagael in the UnShrine! You will need magical protection and Mystic Weapons.
117. There is a rotatable room in this dungeon which can open new paths and close old ones. You will also have to keep popping down to Level 2 to get some of the keys you need for Level 1 and vice versa. There is more than one way exit down to Level 2. The narrow pathways make fighting more dangerous than normal and items of TELEPORT are especially useful. The Assassin should be making good use of an Angel Helm (SPEED TELEPORT) by now.
118. You need to move the skull tile in the middle of the room. Pressing the button changes the direction that the tile will move when the lever is pulled. Pulling the lever moves the tile in the desired direction. Turn to the room solutions section at the back of this manual and look at solution [F] for the answer to this puzzle room.
119. Stand the Runemaster in the SW part of the room and then mix and cast 'Missile, Surround, Healing' at the tile directly east of the pillar so that the Surround part of the spell hits the NE rune on the floor. The spikes will then disappear. When pulled, the lever extinguishes some fire in room 2 revealing a floor switch which will open the door in room 2 when stepped on.
120. Press the blue button to create the bridge to reach the chest in the exit room.
121. Unlike all the other start rooms, there is no way back out from here. Try it and see if you don't believe me!
122. This lever rotates room 4 clockwise.
123. The S exit can only be reached by going down to level 2 and coming back up another way.
124. The button creates a new passage at (**).
125. The door within needs an IRON key.
126. These spikes cannot be turned off and pose no obstacle anyway so don't worry about them.
127. Turn to the room solutions section at the back of this manual and look at solution [E] for the answer to this puzzle room.

-
128. The floor switches teleport whoever stands on them to different sides within the room. It is straight forward enough to solve, once you have the required keys for the required doors. The NE switch opens the path to the chest in the middle of the room.
129. The pillar lever moves a floor tile next to the water, whilst the pillar button changes the direction that the tile will move when the lever is pushed next. You must navigate the tile through the water to reach both chests and ultimately get a character to unlock the door and reach the W side. The switch in the corner will create a floor tile for easier passage across once one character has made it to the other side.
130. You must mix and cast a 'Missile Surround Missile Damage' spell, then a 'Missile Surround Missile Damage Damage' spell, then a 'Missile Surround Missile Damage Damage Damage' spell, then finally a 'Missile Surround Missile Damage Damage Damage Damage'. Aim the spells at the chasm just in front of the E edge of the room. The Surround component will cause the missiles to fly at right angles to the wall and safely hit the E rune.
131. Get three characters on each teleport pad. The fourth character can now approach the chest. The button removes the spikes in front of the chest in room 13.
132. The square switch on the floor creates a path to the chests. Send someone over the floor switches but make sure you can heal them up again after each one. Another character will have to tread on a few of the switches to reach the furniture in the SW corner. The lever creates a corridor N near outside of room 31 (**).
133. The lever creates a floor tile next to the yellow floor switch in room 12.

Detailed Room Solutions

Moonhenge - the mappers nightmare!

Room 2 on the first level is a room that you will have to keep returning to, as it is the start of every path in the level.

The following diagram shows which keys open which doors in room 2 and where the keys are found.

Unlocked doors are usually closely followed by locked ones. The paths mentioned are those that started from this room and are opened with a certain key, e.g the MOON path is that path which begun in room 2 with the door which required a Moon key to open it. These paths only refer to the first level.

Anything on the second level is referred to by a room number only. You will find them in the necessary order if you follow the order described next.

Room 2 - Moonhenge - Level 1

What to do in Moonhenge and when to do it!

DIAMOND - from rm 9 level 2				Unlocked - CRYSTAL via MOON path)
GOLD - from rm 2 level 2				Moon (from Balenhalm)
		Unlocked	-	RUBY
(AZURE - via MOON path)				(from Start rm level 2)

- I. Open the MOON path by unlocking the relevant door with the MOON key.
- II. Find and get the CRYSTAL key. If you go through to room 5 now it will be a dead end along the W/E direction. Return to rm 2.
- III. Go via the unlocked door in the top right hand corner. Open the door with the CRYSTAL key. Move through the upper level of room 7 (the gem room) - through rm 5 (via the N/S path) and through to the Exit room. Move down to level 2. You can't go anywhere except the first room but you can get the RUBY key and return to level 1, room 2.
- IV. Open the RUBY door in room 2, (therefore opening what we shall refer to as the RUBY path). Move through to room 8. Pull the lever in here to rotate room 5. Now return to room 2.
- V. Follow the MOON path from room 2 through room 5 (with the E/W path no longer a dead end). Find and take the AZURE key from room 12, then return to room 2.
- VI. Go through the unlocked door in the bottom left hand corner of room 2 and you will soon have to open the AZURE path with the AZURE key. This leads through the upper level of room 13, through room 14, via the lower level of room 13 and through to the S exit in the Exit room and down to level 2.
- VII. You are now in level 2, room 2. Your options of movement are restricted, so you will eventually end up with the DARK key and AZURE key (from room 5). Go back to level 2, room 2. Open the door which requires the DARK key, then move onwards. You will eventually end up with a GOLD key. Now return to level 1, room 2. Go down the AZURE path.
- VIII. Open the GOLD path in room 2. Go through room 14 and room 17. An IRON key opens the door in room 18. Go to room 19 and go down to level 2 (room 8). Follow the unlocked path in this room. Eventually you will get the BRONZE key. Return to room 8,

-
- level 2. Open the BRONZE door. Go to room 9 and get the DIAMOND key. Now return to room 2, level 1.
- IX. Open the DIAMOND path. Go through to room 19 and down to level 2 (room 10). Get the RUBY key and use it in room 10. Go to room 14 and get the MOON key. Move back to level 1, room 2. Follow the RUBY path to the exit room. Go down to level 2. Use the MOON key. Go through to room 14 and pull the lever here. Now go to room 12 and use the teleport pad to appear on the W side of the room. Go to room 8 and pull the lever there.
- X. Now leave level 2 for level 1 (you will end up in room 19, level 1). You need to return to room 19 but from the other way, so go via the DIAMOND path from level 1, room 2. Go down to level 2, room 10 from room 19, level 1. Take the upper N path (the path with the chest), and go through to room 14. The door in here now opens. Keep going and you will eventually end up in room 7, level 1 (gem room).
- XI. Take the gem (a blue Moon Crystal) and use the other exit back to level 2. Keep moving and you will get back to level 1 (room 11). Make your escape out of Moonhenge with the crystal and a skull key.

Simple when you know how!

WARNING! Do not read the following room solutions unless instructed to.

Note that the following solutions always have the Runemaster casting the necessary spells. It is possible in some rooms to have other characters use equivalent scrolls or other magical items if they are available instead.

A. Treihadwyl - Level 2 - Room 10

The aim of this room is to create a path to the S door exit. This is achieved by pulling the lever and casting 'Missile Damage' and 'Missile Damage Damage' spells.

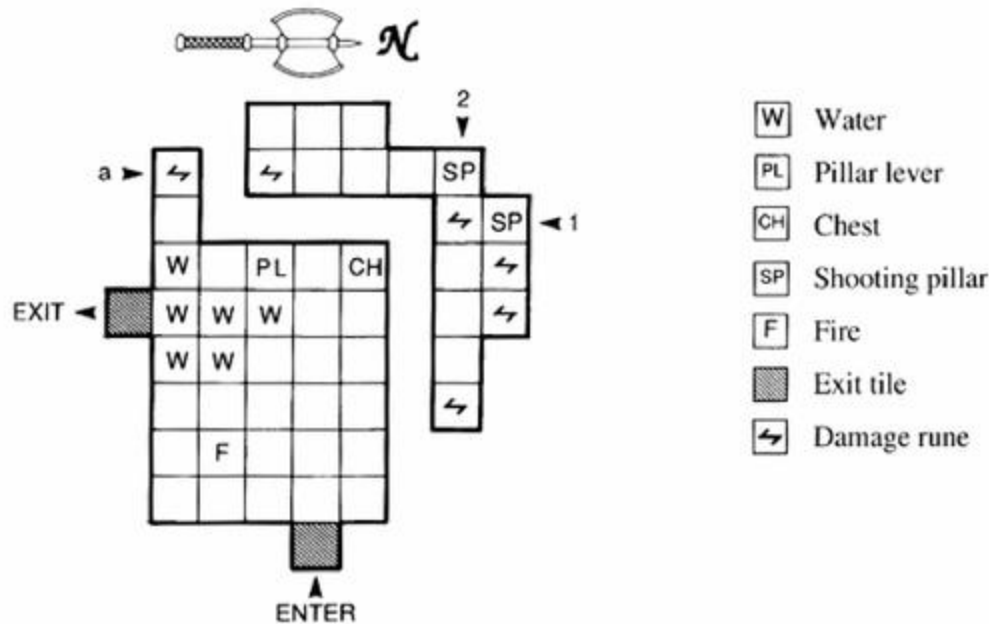

- I. Get the Runemaster to cast 'Missile Damage' at rune (a). One of the water tiles will turn into a skull tile.
- II. Cast 'Missile Damage Damage' at rune (a). Another water tile is turned into a skull tile. The pillar lever can now be reached.
- III. Get another character to pull the lever. Shooting pillar 1 will turn to face south.
- IV. Cast 'Missile Damage' at rune (a) once again. Shooting pillar 2 will turn to face east.
- V. Pull the lever. Shooting pillar 1 will turn to face east.
- VI. Cast 'Missile Damage' at rune (a) again. A skull tile will revert to water.
- VII. Cast 'Missile Damage Damage' at rune (a). A skull tile will appear next to the S exit, but another will turn back to water.
- VIII. Pull the lever. Shooting pillar 1 will turn to face south.
- IX. Cast 'Missile Damage' at rune (a). Shooting pillar 2 will turn to face south.
- X. Pull the lever once again. Shooting pillar 1 will turn to face east.
- XI. Cast 'Missile Damage' at rune (a). This will remove a skull tile, isolating the character by the lever.
- XII. Cast 'Missile Damage Damage' at rune (a). The path to the S door is completed and the door will open.

Note that there is a strong chance that the character by the pillar lever will be attacked as soon as the south door opens. For this reason, it is probably a good idea to have your strongest fighter in this position.

B. Fagranc - Level 1 - Room 28

The aim of this room is to open the chest in the NW area by pulling levers and casting 'Missile Damage' spells.

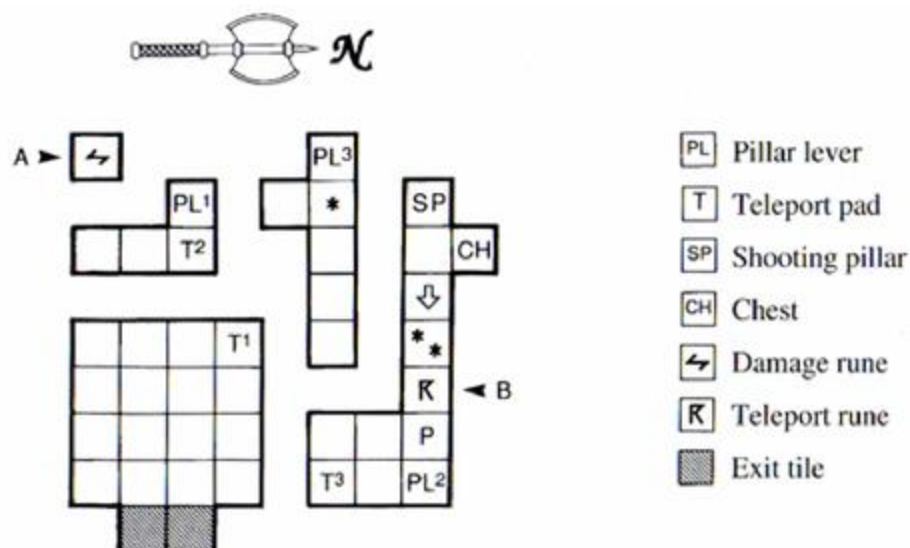

- I. Stand a character (e.g Berserker) on Teleport pad 1. Get the Runemaster to cast 'Missile Damage' at rune A once. The shooting pillar will fire a 'Missile Teleport' spell at rune B.
- II. The Berserker is teleported to Teleport pad 2, which is next to pillar lever 1. Pull the lever. The Berserker will be teleported to Teleport pad 3. Move him one step off the pad to face pillar lever 2.
- III. Stand another character (e.g Assassin) on Teleport pad 1. Get the Runemaster to cast 'Missile Damage' at rune A once.
- IV. The Assassin is teleported to Teleport pad 2. Get him to pull pillar lever 1 and he will be moved to Teleport pad 3.
- V. Now get the Berserker to pull pillar lever 2. The Assassin will be teleported to position *. Get him to pull pillar lever 3. Two skull tiles will appear on the floor.
- VI. Get the Assassin to walk to position **. A skull tile behind him will disappear.
- VII. The Runemaster must cast 'Missile Damage' at rune A again. The shooting pillar will once again fire a 'Missile Teleport' spell. The Assassin will be hit by the spell as he is standing in the way.
- VIII. Switch to the Assassin and select the floor tile immediately in front of the chest. He will instantly teleport to that spot. Get him to open the chest and take the key from inside.

Note that if you step on the tile with the arrow on it, the character will be teleported back to Teleport pad 1. You can use this if you wish to get back to the other side once you have the key, or you can just instruct the last character (Troubadour) to leave the room instead.

C. Dark Tower - Level 1 - Room 32

The aim of this room is to get across to the other side. This can only be achieved by quick split second timing and the casting of 'Missile Teleport' spells.

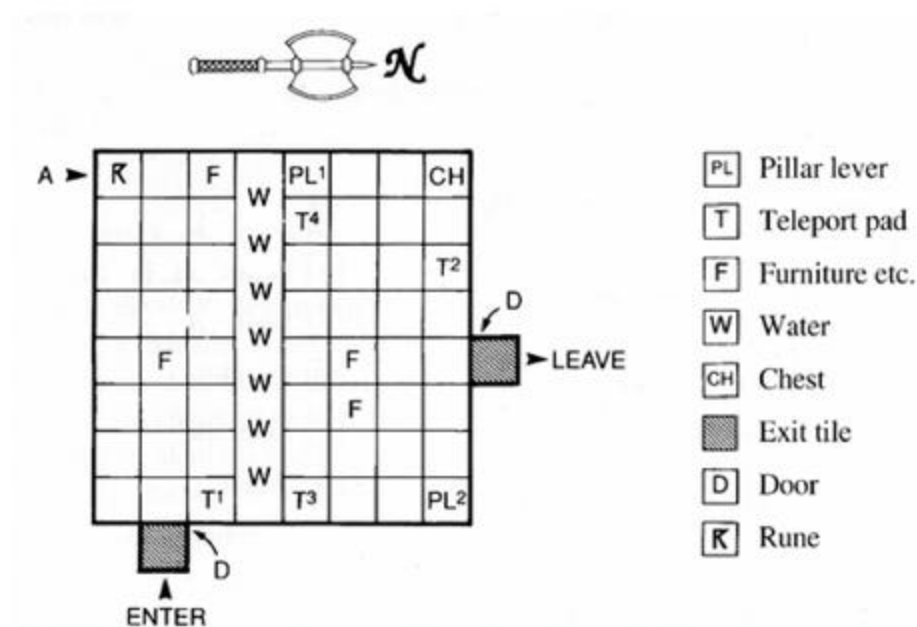

- I. Position the Assassin on Teleport pad 1 and stand the Berserker and Troubadour on the W and S sides of Teleport pad 1 respectively. Switch to the Berserker and select Teleport pad 1. He won't move onto it because the Assassin is already occupying that spot and cannot move out of the way, but the Berserker will be facing east towards the pad. Do the same for the Troubadour so that he faces north towards the pad without actually stepping onto it.

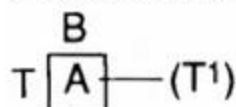

- II. Now get the Runemaster to cast 'Missile Teleport' at rune A.
- III. Immediately switch to the Berserker and select the Teleport pad 1 tile. He will step onto the pad as the Assassin will have been teleported to Teleport pad 2 and will be unable to return.
- IV. Get the Assassin to pull pillar lever 2. A floor tile will appear and bridge the water that divides the room in two.
- V. Position all of the characters on Teleport pad 1 first, then pad 2, then pad 3 and finally pad 4. Now get someone to pull pillar lever 1 to open the north door.

Note that timing is critical. You might have to try this a few times before you are successful.

D. Dark Tower - Level 3 - Room 14

The aim of this room is to reach the NE chest and retrieve the key that lies inside.

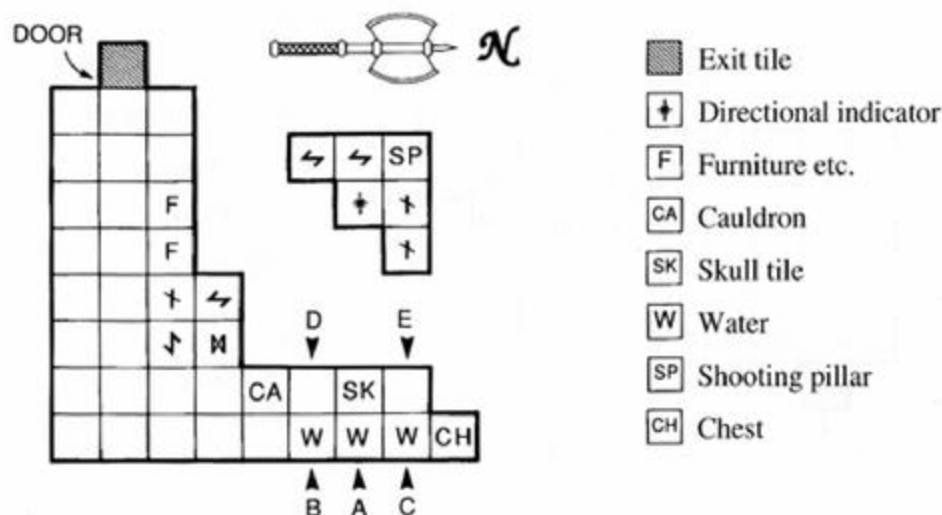

You will be required to cast a number of spells in here:

Missile Damage, Missile Damage Damage
 Missile Healing, Missile Healing Healing
 Missile Dispel
 Missile Paralyze

You must guide a skull tile through water so that a character can reach the chest. Note that each spell has a different effect when cast on the correct floor rune.

Missile Damage makes the direction that the skull tile will move EAST.
 Missile Damage Damage makes the direction SOUTH.
 Missile Healing makes the direction NORTH.
 Missile Healing Healing makes the direction WEST.

You MUST cast any Damage spells on the Damage floor rune.
 The shooting pillar MUST be facing its own Damage floor runes BEFORE any Damage spells are be cast by the Runemaster.

You MUST cast any Healing spells on the Healing floor rune.
 The shooting pillar MUST be facing its own Healing runes BEFORE any Healing spells are cast by the Runemaster.

Missile Paralyze spells MUST be cast on the Paralyze rune on the floor.
 The Paralyze rune on the floor will turn the shooting pillar either south (towards its own Damage runes) or east (towards its own Healing runes).

Missile Dispel spells MUST be cast on the Dispel rune on the floor.
 When hit, this will in turn move the skull tile in the water in the relevant direction.

Applying these rules, you need to do the following to reach the chest:

- I. Move the skull tile east to position A, then south to position B.

-
- II. Move a character to position D.
 - III. Move the skull tile north to position A and W back to its original position.
 - IV. Move the character to position F.
 - V. Move the skull tile east to position A then north to position C.
 - VI. Get the character to step onto the skull tile and open the chest.

E. Fagranc - Level 3 - Room 17

The aim of this room is to reach the west exit. This is achieved by pushing buttons and levers, by stepping onto teleport pads and by casting a 'Missile Dispel Paralyze Teleport' spell.

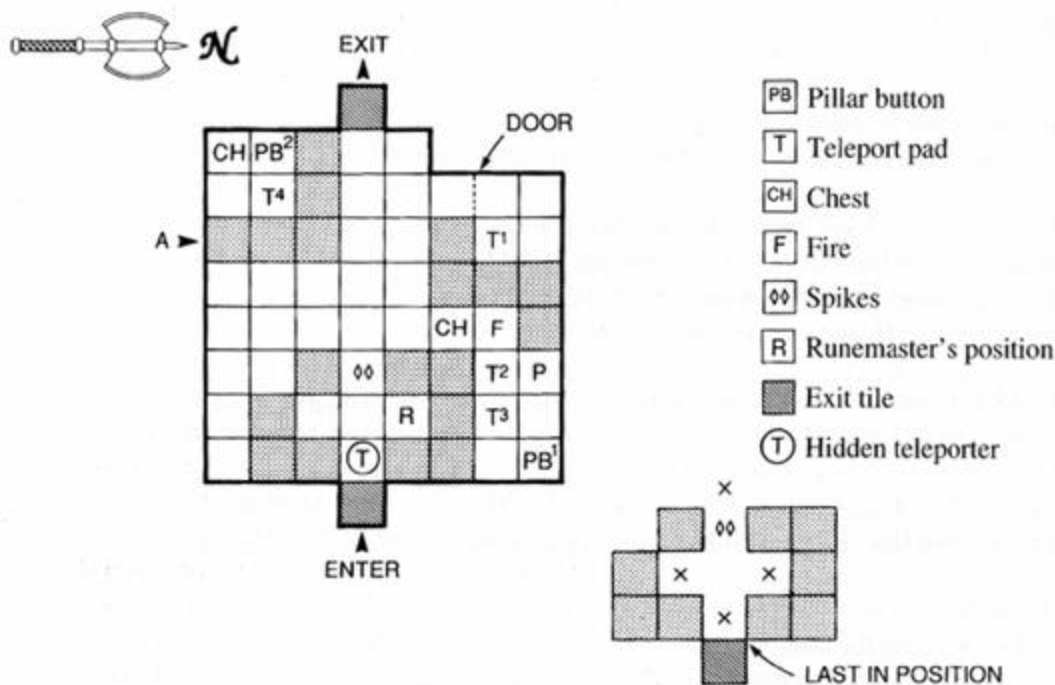

- I. When you enter the room, ensure that the Runmaster is NOT the party leader.
- II. The hidden teleporter will teleport the first two characters to positions beyond the floor spikes.
- III. The remaining two characters (i.e Runmaster and one other, e.g Assassin) will be confined to moving in the few floor tiles available between the entrance door and the spikes.
- IV. The monsters in this room will have to be dealt with by the first two characters (e.g Berserker and Troubadour).
- V. Get the Berserker to open the chest near the spikes and take the key within. Use this key to open the NW door. Stand on Teleport pad 1 in the area behind this door. The Berserker will be rapidly teleported between Teleport pads 1 and 2.
- VI. Stand the Runmaster at position R. Ready a 'Missile Dispel Paralyze Teleport' spell. Now cast it at Teleport pad 2 and with any luck you will have frozen the Berserker there.
- VII. Switch to the Berserker and select the tile immediately in front of pillar button 1. This will teleport him to that position, avoiding having to stand on Teleport pad 3 which lies in-between.
- VIII. When paralyze wears off, get the Berserker to push the blue button on pillar button 1. The floor spikes will now lower to let another character go past.
- IX. Get another character (e.g Troubadour) to stand on Teleport pad 1, whilst the Berserker is still standing by the blue button.
- X. Now get the Berserker to stand on Teleport pad 3 and he will be teleported to pad 4. Open the chest and take the key. Press the button on pillar button 2 to add a floor tile at position A, which will allow the Berserker to reach the W door and unlock it.

Note that on the return journey through this room (west to east door), the east door will have locked itself. It needs a gold key to open it. To be able to stand by the door and unlock it

without being moved by the hidden teleport pad, you need to stand one character on the W side of the spikes, and two on the S and N ends of the cross shaped area in front of the door. Lastly stand a character on the tile next to the door and unlock it.

F. The Unshrine - Level 1 - Room 26

The aim is to reach the west exit by moving the skull tile through the water via a button and a lever.

Be warned that unlike most other puzzle rooms, you can be attacked by wandering monsters in here!

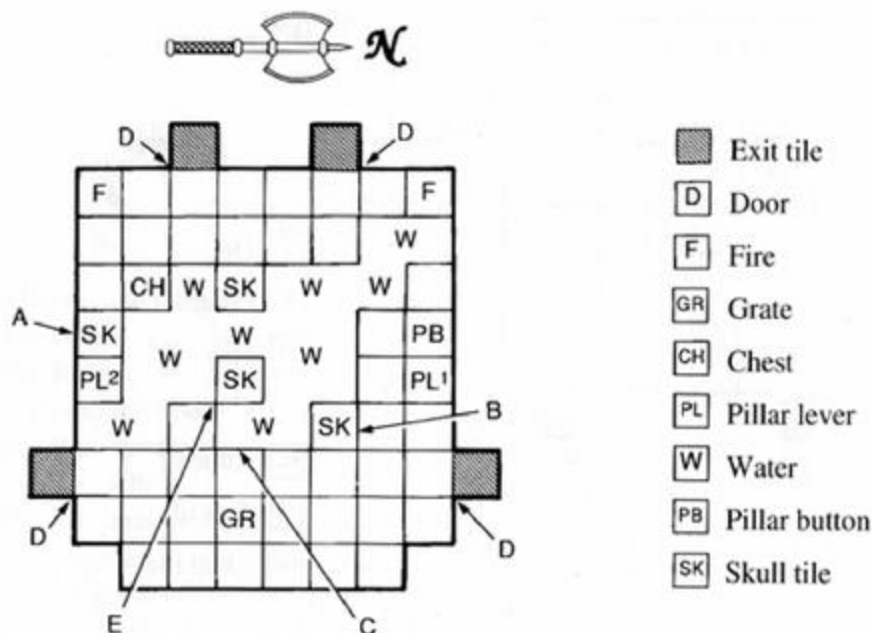

The lever moves the tile. The button changes the direction that it will move in.

- I. Push pillar lever 1 once and the skull tile at position A will move one step to the east.
- II. Push the pillar button once to change the direction to south.
- III. Push pillar lever 1 twice and the skull will move south twice.
- IV. Push the pillar button once to change the direction to west.
- V. Push pillar lever 1 once to move the skull in front of pillar lever 2.
- VI. Push pillar lever 2 once and the skull will move from west position B.
- VII. Push pillar lever 2 once again and the skull will move west again to position C.
- VIII. Place a character (preferably the Berserker) on the middle tile at position E. There might be monsters to fight in the west half of the room!
- IX. Step off the skull tile (by pillar lever 2).
- X. Move this skull tile to join up with the skull tile at position E, with the skull tile west of it. This will allow the Berserker to walk over to the west side, (i.e. east, north, north, east, east).

G. Fagranc - Level 8 - Room 30

The aim is to reach the long chest and get the key from within. This will involve the temporary sacrifice of one of your own characters!!

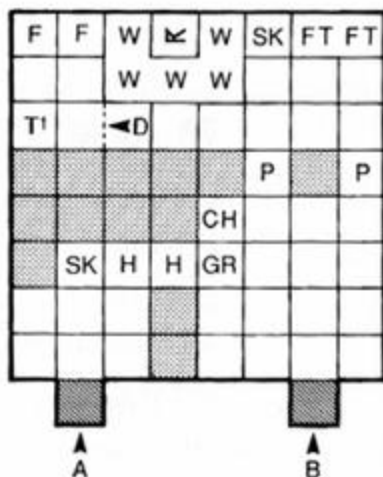

- F** Furniture/long chest
- W** Water
- FT** Fire trench
- T** Teleport pad
- D** Door
- P** Pillar
- H** Hay
- GR** Grate
- ☞** Rune (Teleport)
- Exit tile
- SK** Skull tile
- CH** Chest

- I. Stand a character (NOT the Runemaster) on the skull tile in the west half of the room.
- II. Get the Runemaster to kill that character. Leave the bones exactly where they are.
- III. Leave the room via exit A. Return to the room via entrance B.
- IV. Resurrect the dead character with a 'Missile Vivify' spell.
- V. Cast 'Missile Teleport' at the northern rune on the floor. This will teleport the resurrected character from the skull tile on the west side to the northern skull tile.
- VI. The remainder is quite straightforward. Teleport pad 1 will take the character to the east side once the key has been taken from the long chest.

H. The King - Level 1 - Room 30

The aim is to reach the NE exit. Getting there is the problem!

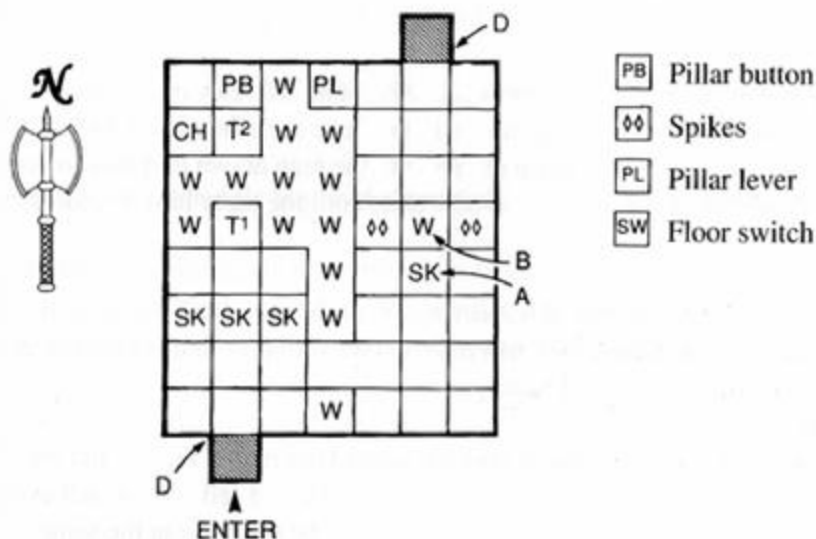

- I. Line up three of the characters on the three west side skull tiles. The Runemaster should be one of them.
- II. Position the last remaining character on teleport pad 1 to be teleported to teleport pad 2.
- III. The character by teleport pad 2 should open the chest and take the key.
- IV. The Runemaster must (temporarily) kill the character on teleport pad 2. He must then step onto the floor switch and cross over into the east side of the room.
- V. The Runemaster should now bring back the dead character on pad 2 by casting a 'Missile Vivify' spell.
- VI. The Runemaster must now stand on the skull tile at position A.
- VII. The character at pad 2 must press the pillar button. A new skull tile is placed at position B.
- VIII. The Runemaster can now walk over position B and reach the pillar lever. Pushing the lever will lower some of the spikes.
- IX. The key from the chest will open the north door.

I. The King - Level 2 - Room 2

This room is the centre of attention for the whole of this level within the King's castle. The ultimate aim is to create and remove corridor exits from certain rooms within the level. This is achieved by toggling the four floor switches in this room on or off. Only by doing this will you get through the door in this room and be able to reach the staircase that leads to the final level!

Each switch has the following effect when turned on.

Switch	Affected Room	Possible exits (not available all at once)
Green	3	N, S, E, W
Red	5	N, S, E, W
Orange	6	N, S, E, W
Blue	20	N, E, W

What actually happens is that an 'L' shaped corridor is rotated around the relevant room when the correct button is turned on. When this corridor moves it will have the effect of adding new exits and removing previously available ones. Keep referring to the map drawn by Elliot to see this happening. Note that you will not actually see the new exits until the party have explored them.

The party will have to do a substantial amount of wandering to and from room 2, and that to explore certain exits from the affected rooms they will have to take different routes to get there due to the removal of certain corridors.

It is best to imagine the right angled 'L' corridor in position around the room. You should then be able to calculate whether a new exit is available or not. The table above tells you which exits are possible from each room. It is obvious that N and S exits cannot be available at the same time from the affected rooms due to the right angled shape of the 'L' corridor, and neither can E and W.

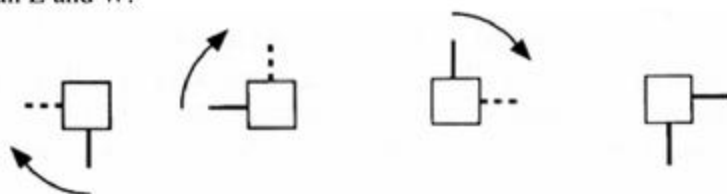

Imagine that you have just selected Elliot and you are looking at one of the affected rooms. At the start the room seems to only have a south exit. That exit appears because you have visited the room before. What the map doesn't show is that it also has an east exit which you did not investigate because (for example) you didn't have the required key or you were fleeing at the time.

Your party trot off to the room and use this east exit then come back and press the button in room 2 that affects that room. The 'L' corridor moves clockwise around the room. The east exit has now been disabled. The south exit still exists because the corridor from the east exit has now moved down into its position. What you won't know is that a new west exit is now available. By popping back to this room you can explore the west exit so that it appears on the game map. The next time you press the button on room 2, the corridor moves round again in a clockwise direction, creating a new undiscovered north exit and removing the south exit. If you want to explore the room now, a new route will have to be found as you can only get in via the west exit. This logical progression is illustrated above.

You can see that without understanding what is happening, it would appear that the buttons are randomly taking and creating different exits from certain rooms. Knowing means that you can easily think things through and calculate which button to turn on and when to get to the area you want. The King's best inventors spent months designing this level to thwart any would be invaders from reaching his private chambers.

Note that the 'L' corridor can move clockwise or anti-clockwise. It all depends on the room that is being affected.

Now that the principle has been explained, we must look at room 2 in detail.

The aim is to eventually reach the topaz key which lies on the skull tile in the middle of the room. At the start this is blocked by a pillar. The key will allow you to open the door in here and get nearer to the staircase which leads to the final level.

J. The King – Level 2 – Room 2

We already know that:

Room 3 is affected by the GREEN switch
Room 5 is affected by the RED switch
Room 6 is affected by the ORANGE switch
Room 20 is affected by the BLUE switch.

Each switch is located behind a locked door. The required keys are:

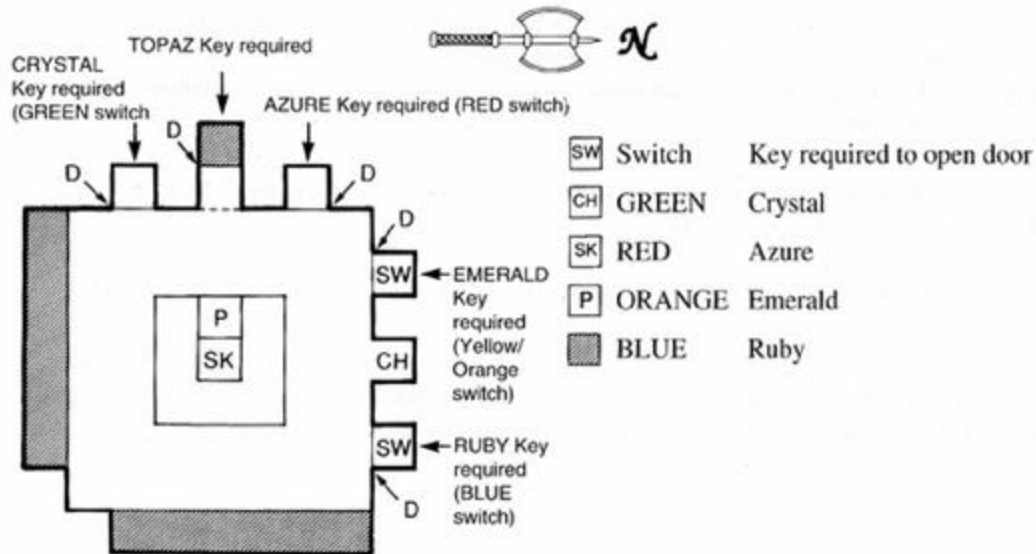

You need to have got the Crystal key from room 4 before following these instructions. It is used to open the door which contains the GREEN floor switch.

- I. Before you step on the GREEN switch, room 3 has W and S exits. Step on GREEN once. Room 3 exits are now W and N. To reach room 3 and explore the new N exit you must go via room 5. (Note the corridor rotates clockwise around room 3). Take the Azure key from room 7 and return to room 2.
- II. Before you step on RED, room 5 has E and S exits. Step on RED once. The exits are now E and N. To reach room 5 and explore the new N exit you must also manipulate room 3 to create a path of corridors that lead the room. (Note the corridor rotates anti-clockwise around room 5).
- III. We need to give room 3 W and S exits. Stepping on/off GREEN three times should do this. Now go to room 5 via room 3. Get the Bronze key from room 10. Now move to outside room 11 via room 2 and use the Bronze key. Go to room 12 and get the Gold key. Open room 13 with this key, and take the Bronze key from room 14. Open the east door in room 13. Go to room 15 and room 16. Get the Emerald key and return to room 2.
- IV. Before you step on the ORANGE switch, room 6 has W and N exits. Step on ORANGE three times so that you now have N and E exits. (Note that the corridor rotates in an anti-clockwise direction). Go to room 6, room 19, room 20 and room 22. Take the Iron key. Open the west door in room 19 with it and go to room 23. Take the Diamond key and return to room 2.

-
- V. You need to create S and W exits for room 6. Once you've done this, room 5 will need E and S exits so that you can reach room 6. Go to room 6 and go south. Open the south door outside room 24. Enter. Take the Ruby key and return to room 2.
- VI. Before you step on the BLUE switch, room 20 has W and N exits. Step on BLUE once. The exits are now N and E. (The corridor moves in a clockwise direction). Go to room 20, then room 25 and through to room 26. Take the Ornate key and go to room 4. Open the door and pull the lever, (which removes the pillar in room 2). Return to room 2. Take the Topaz key from the middle of the room and open the north door. Go N.

You are on your way to reaching the final level of the King's castle. Have you got what it takes to become Legendary?

APPENDIX A – Object Effects

Use this list as a reference whenever you come across a new object in the game. Objects must be used extensively during the game if you are to battle through to the end.

The level of a spell indicates how powerful it's effect will be, Level 1 being the weakest and Level 4 being the strongest. When a spell is mentioned without a number it means the effect is not variable. The spell numbers refer to the "spells for objects" list.

Remember that Armour Class (AC) is better the lower the number, so all items that boost armour are negative (-) numbers.

When an item is described as a 'thief weapon' it means that the Assassin can attempt his back attack when using it.

Exclusions show that the indicated character class cannot use that item.

B = Berserker, T = Troubadour, A = Assassin, R = Runemaster

ALL LEGEND ITEMS

Cost	Item	Effect	Exclusions
80	helm	AC-1	R
120	golden helm	Level 2 spell 10	A,R
560	frost helm	Level 2 spell 14	A,R
130	mithril helm	AC-3	R
320	blood helm	Level 2 spell 19	R
300	cloud helm	Spell 21	A,R
520	angel helm	Spell 8	R
1510	dragon helm	Level 2 spell 20	A,R
330	holy helm	Spell 16	R
450	winged helm	AC-5	R
760	serpent helm	Level 3 spell 1	A,R
1000	hero helm	Berserk	R
850	war helm	AC-7	A,R
1800	doom helm	AC-9	A,R
750	chaos helm	Level 2 spell 25	R
2350	death helm	AC-11	A,R
410	sun amulet	CON+4	-
430	moon amulet	AC-3	-
400	serpent amulet	ST+3	-
400	amber amulet	DEX+3	-
450	dragon amulet	DF+25	-
510	cloud amulet	INT+5	-
25	leather boots	AC-1	-
90	iron boots	AC-3	A,R
600	elf boots	AC-5	-
460	golden boots	DF+20	-
1760	crystal boots	AC-7	A,R
2740	cloud boots	SP+10	-
30	leather buckler	AC-1	R
85	buckler	AC-2	R
440	arc shield	AC-4	R
1550	battle bane	AC-9	A,R
450	iron shield	AC-5	A,R
260	golden shield	Level 3 spell 10	A,R
580	bane shield	Spell 5	A,R

800	dragon shield	Level 4 spell 19	A,R
1100	war shield	AC-7	A,R
1630	serpent shield	Full heal	A,R
2550	heron shield	AC-13	A,R
10	robes	AC-1	-
45	leathers	AC-3	R
75	chain mail	AC-5	A,R
125	plate mail	AC-5	T,A,R
200	bracers	AC-4	-
1500	arcane bracers	AC-15	-
700	mithril chain	AC-10	A,R
950	mithril plate	AC-12	T,A,R
900	stealth bracers	AC-9	-
1750	blood leathers	AC-8	R
1950	crystal chain	AC-18	A,R
2400	crystal plate	AC-20	T,A,R
3000	holy crystal	AC-25	A,R
15	leather gloves	AC-1	-
100	amber ring	Spell 3	-
95	gauntlets	AC-3	A,R
180	chaos gloves	AC-2	B,T,A
115	serpent ring	Level 2 spell 0	-
250	cloud ring	Spell 21	-
420	dragon ring	Level 3 spell 19	B,T,A
780	blood ring	AC-4	-
550	stealth gloves	DEX+4	B,T,R
150	sun ring	Spell 2	-
1400	moon ring	Invisibility	-
540	mithril gloves	AC-5	A,R
1810	battle gloves	AC-7	A,R
10	dagger	Thief weapon	-
40	short sword	AF+10, DF+20	A,R
50	staff	AF+28, DF+30	-
100	broad sword	AF+30, DF+10	A,R
140	mithril dagger Thief weapon	AF+5	B,T,R
500	battle staff	AF+25, DF+40	-
120	battle axe	AF+20	T,A,R
250	mithril blade	AF+15, DF+30	A,R
350	mithril sword	AF+20, DF+15	A,R
650	mithril axe	AF+25	T,A,R
800	broad axe	AF+40	T,A,R
2000	hero staff	Berserk	-
1200	heron blade	SP+5	A,R
1700	death axe	ST+2	T,A,R
950	stealth blade Thief weapon	DEX+3	B,T,R
1900	death blade Thief weapon	ST+4	B,T,R
2800	arcane sword	AC-10	B,T,A
1790	doom blade	ST+2	A,R
2200	blood axe	AF+88, DF+10	T,A,R
3000	vorpal blade	AC-31, AF+100, DF+80	A,R
3000	slugger	Mega Axe	T,A,R
3000	crystal blade Thief weapon	AF+165, DF+10	B,T,A
N/A	Ancient staff	INT+20, AF+50, DF+80	B,T,A
N/A	mystic axe	Made weapon	T,A,R
N/A	mystic sword	Made weapon	B,A,R
N/A	mystic dagger	Made thief weapon	B,T,R
N/A	mystic staff	Made weapon	B,T,A
N/A	bag of gold	Money!	-
N/A	bag of bat wings	Wing of Bat (ingredient)	B,T,A
N/A	bag of yellow powder	Brimstone (ingredient)	B,T,A

N/A	bag of roots	Mandrake (ingredient)	B,T,A
N/A	bag of crystals	Crystal (ingredient)	B,T,A
N/A	bag of venom sacs	Hedjog Venom (ingredient)	B,T,A
N/A	bag of ugly teeth	Dragon Tooth (ingredient)	B,T,A
N/A	bag of black berries	Nightshade (ingredient)	B,T,A
N/A	bag of fiery claws	Phoenix Claw (ingredient)	B,T,A
1000	amber staff	Spell 22	B,T,A
680	moon staff	Spell 9	B,T,A
730	crystal staff	Level 4 spell 31	B,T,A
1450	serpent staff	Level 4 spell 27	B,T,A
2500	sun staff	Level 4 spell 30	B,T,A
2000	dragon staff	Level 4 spell 24B,T,A	
240	amber wand	Level 3 spell 17	B,T,A
195	moon wand	Spell 16	B,T,A
275	cloud wand	Spell 21	B,T,A
700	dragon wand	Level 3 spell 23	B,T,A
750	serpent wand	Level 3 spell 26	B,T,A
850	sun wand	Level 4 spell 28	B,T,A
350	crystal wand	Level 2 spell 18	B,T,A
20	scroll (green)	Level 1 spell 0	-
25	scroll (brown)	Spell 12	-
60	scroll (light blue)	Spell 16	-
55	scroll (green)	Spell 5	-
60	scroll (dark blue)	Level 1 spell 14	-
45	scroll (blue)	Level 2 spell 13	-
25	scroll (green)	Level 2 spell 0	-
50	scroll (brown)	Level 1 spell 19	-
60	scroll (dark grey)	Berserk	-
40	scroll (light grey)	Spell 7	-
35	scroll (red brown)	Level 2 spell 10	-
30	scroll (green)	Level 3 spell 0	-
55	scroll (light yellow)	Spell 6	-
60	scroll (light brown)	Level 2 spell 11	-
40	scroll (green)	Level 4 spell 1	-
65	scroll (white)	Level 4 spell 25	-
400	craven image	8 enhanced prayers (luck)	-
800	holy relic	16 enhanced prayers (luck)	-
N/A	skull key	-	-
N/A	iron key	-	-
N/A	silver key	-	-
N/A	bronze key	-	-
N/A	gold key	-	-
N/A	diamond key	-	-
N/A	crystal key	-	-
N/A	azure key	-	-
N/A	emerald key	-	-
N/A	ruby key	-	-
N/A	topaz key	-	-
N/A	ornate key	-	-
N/A	dark key	-	-
N/A	moon key	-	-
N/A	unkey	-	-
N/A	permit	Allows first visit to King	-
N/A	serpent crystal	Power Crystal (green)	-
N/A	moon crystal	Power Crystal (blue)	-
N/A	dragon crystal	Power Crystal (red)	-
N/A	chaos crystal	Power Crystal (orange)	-
30	serpent potion	Level 1 spell 0	-
50	power potion	Spell 8	-
50	cloud potion	Spell 21	-

75	moon potion	Invisibility	-
35	amber potion	Spell 3	-
35	serpent potion	Level 2 spell 0	-
70	hero potion	Berserk	-
45	golden potion	Spell 2	-
40	serpent potion	Level 3 spell 0	-
60	bronze potion	Spell 4	-
75	serpent potion	Full heal (from Temples)	-
75	dragon potion	Spell 15	-
25	horn	Basic instrument	B,A,R
130	lyre	CON+2	B,A,R
130	mandolin	DEX+2	B,A,R
280	harmonic lyre	Spell 6	B,A,R
550	crystal mandolin	Spell 21	B,A,R
760	diamond horn	Spell 4	B,A,R
250	battle horn	Berserk	B,A,R
1150	angel harp	Spell 15	B,A,R
2250	arcane mandolin	Level 4 spell 29	B,A,R
70	mixing bowl	Runemaster's bowl	B,T,A

The Spells for objects:

0	heal
1	heal surround heal
2	regeneration
3	antimage
4	speed
5	make-weapon
6	regeneration surround regeneration
7	antimage surround antimage
8	teleport speed
9	make-weapon surround make-weapon
10	forward damage
11	forward disrupt
12	forward dispel
13	forward paralyze
14	surround paralyze
15	regeneration speed antimage
16	surround thrall
17	missile damage
18	missile disrupt
19	surround damage
20	surround disrupt
21	teleport
22	regeneration speed antimage surround regeneration speed antimage
23	missile damage surround damage
24	missile disrupt surround disrupt
25	forward vivify
26	missile vivify heal
27	continuous vivify heal
28	missile damage surround missile damage
29	surround missile disrupt
30	antimage surround damage missile damage surround damage missile damage
31	missile dispel paralyze continuous paralyze

It can often be hard to decide which weapon to use. Most of the time a quick check on Af and Df will help your decision but the only real test is to try out a weapon and see what damage it does. The rough order of weapon effectiveness is:

Berserker:	dagger short sword staff broad sword battle axe mithril blade mithril sword battle staff mithril axe broad axe hero staff heron blade death axe doom blade blood axe vorpall blade slugger
Troubadour:	dagger short sword staff broad sword mithril blade mithril sword battle staff heron blade hero staff doom blade vorpall blade
Assassin:	dagger mithril dagger stealth blade death blade crystal blade
Runemaster:	dagger staff battle staff hero staff ancient staff arcane sword

Until near the end of the game (when you begin using Sluggers and Vorpall Blades), you will probably find that Mystic Weapons are the most effective weapon available (those made by the Make-Weapon rune). The Ancient staff is an exception to this, of course.

A hidden advantage to Mystic weapons is the strength boost they bestow giving extra damage in combat. They are, of course, lost when hit by DISPEL and you may also feel that you just don't have enough free Inventory slots to be able to carry them.

Don't forget that to use the Berserk option on the Hero Staff you must click on the staff itself else the character will fight without using the Berserk option of the staff.

APPENDIX B – Magic Runes and their cost

All of the runes are purchased from the Ancient, who lives in the mountain cave near Treihadwyl.

Name	Cost	Type
FORWARD	500	Director
CONTINUOUS	1,500	Director
PARALYZE	1,500	Effector
SPEED	1,500	Effector
THRALL	1,500	Effector
DISPEL	2,000	Effector
SURROUND	2,000	Director
ANTIMAGE	3,000	Effector
MAKE WEAPON	3,000	Effector
TELEPORT	4,000	Effector
REGENERATION	8,000	Effector
DISRUPT	15,000	Effector
VIVIFY	20,000	Effector

The following are already in the Runemaster's possession at the start of the quest:

Name	Cost	Type
MISSILE	N.A.	Director
HEALING	N.A.	Effector
DAMAGE	N.A.	Effector

Note that there are runes that you **MUST** have to be able to solve some of the dungeons. Therefore you should aim to get **ALL** of them.

APPENDIX C – Apothecaries

Location	Ingredients
Pongbarn:	Crystal Dragons Tooth Phoenix Claw
Creyndor:	Brimstone Crystal Hedjog Venom Nightshade Phoenix Claw
Leercote:	Wing of Bat Crystal Dragons Tooth Phoenix Claw
Groghurst:	Brimstone Crystal Hedjog Venom Dragons Tooth Nightshade
Smathost:	Wing of Bat Brimstone Mandrake* Hedjog Venom
Martindale:	Brimstone Crystal Hedjog Venom Nightshade
Titanshal:	Wing of Bat Dragons Tooth
Brodifird:	Phoenix Claw
Balenhalm:	Hedjog Venom Nightshade Phoenix Claw
Dak's Pond:	Wing of Bat Brimstone Crystal Nightshade Phoenix Claw
Hill's End:	Hedjog Venom Phoenix Claw
Zorendorf:	Wing of Bat Mandrake* Dragon tooth Nightshade

* Zorendorf and Smathost are the only vendors of Mandrake.

Ingredient prices

Ingredients vary in price, depending on when and where you are buying them. At the start of the game, Smathost is cheapest but prices change every two days so you've got to be quick!

Wing of Bat	3 gold (fixed price)
Brimstone	5 gold - 8 gold
Mandrake	7 gold - 10 gold
Hedjog venom	9 gold - 12 gold
Crystal	11 gold - 14 gold
Dragon's tooth	13 gold - 16 gold
Nightshade	15 gold - 18 gold
Pheonix claw	17 gold - 20 gold

APPENDIX D - Locations

Holy Temple locations:	Martindale Leercote Zorendorf Goriah Brodfird Balenhalm Dak's Pond Hill's End
Artificer locations:	Creyndor Goriah Pongbarn Dak's Pond Titanshal Smathost Treihadwyl
Blacksmith locations:	Zorendorf Creyndor Goriah Pongbarn Balenhalm Groghurst Titanshal Smathost Treihadwyl

APPENDIX E - Rewards

1,000 - Advance payment from the King for ridding Fagranc of evil.

2,000 - For finding the Ancient staff and returning it to the Ancient.

It is probably not worthwhile collecting the reward from the Ancient as the staff is worth far more than 2,000 gold in terms of usefulness. Not only is it a powerful weapon but it also adds twenty to the Runemaster's intelligence score making all of his spells more effective.

Unfortunately, any time you visit the Ancient whilst carrying the staff he will take it from you and give you the cash. The only way you can avoid this is by dropping the staff in a dungeon (eg: Treihadwyl) before going to see the Ancient and returning to collect it afterwards.

The Four Power Crystals

Crystal Type	Colour	Location
Serpent Crystal	Green	Balenhalm - Level 1
Moon Crystal	Blue	Moonhenge - Level 1
Dragon Crystal	Red	Unshrine - Level 2
Chaos Crystal	Orange	Fagranc - Level 8

Ensure that the Crystals are given to the keeps (it doesn't matter which) as each time you do so powerful magic is unleashed:- all of the enemy banners currently on the map are destroyed and any Town, Village or Keep currently occupied by the enemy is liberated. You need to give all four Crystals to the Keeps to complete the game.

The price of Experience

Each time you successfully train up to a new level, you have to pay the Guild a fee. The amount depends on the level of experience you are able to reach.

Level	Experience	Cost
1 to 2	2000	500
2 to 3	6000	1,000
3 to 4	12000	1,500
4 to 5	25000	2,000
5 to 6	50000	2,500
6 to 7	100000	3,000
7 to 8	200000	3,500
8 to 9	300000	4,000
9 to 10	420000	4,500
10 to 11	550000	5,000
11 to 12	700000	5,500
12 to 13	850000	6,000
13 to 14	1000000	6,500

... ask the Guild-Master if you need to know any further.

As you can see, each time you go up a level the cost increase is another 500 gold. You don't need to visit the Guild every time you are due a level break as you can train up as many levels as you have experience for each time.

APPENDIX F – Magic Spells

The spell-system in Legend is the most flexible so far presented in a computer-based adventure game and you are advised to experiment with rune combinations to find spells that suit your personal playing style.

The game manual covers most you need to know except that, as well as covering more area, a Surround component also boosts the remainder of the spell.

Many runes don't benefit from boosting but Damage, Heal, Paralyze, Disrupt and Vivify do (a stronger Vivify will give you more luck - see 'Adieu Sweet Dullard' in Appendix G).

Heal, Damage and Disrupt can be worth using multiple times in the same spell, for example, 'Heal Heal' is stronger than 'Heal'.

Note that casting 'Missile Paralyze Paralyze' is not better than 'Missile Paralyze' as the duration of paralysis is taken only from the last Paralyze and so the first of a double Paralyze is wasted. Continuous Paralyze is, of course, another matter altogether.

Here are a few suggestions for spells that you may find useful as you acquaint yourself with the system:

Missile Damage
Missile Damage Damage ...
Heal
Missile Heal
Missile Heal Heal ...
Missile Dispel Damage Damage ...
Missile Dispel Paralyze
Teleport
Surround Damage
Surround Heal
Antimage Surround Antimage
Regeneration Surround Regeneration
Antimage Regeneration Surround Make-Weapon Antimage Regeneration
Speed Surround Speed
Missile Speed Teleport
Missile Continuous Heal Heal Heal
Surround Damage Missile Damage Surround Damage Missile Damage
Surround Thrall Missile Thrall Surround Thrall Missile Thrall
Surround Paralyze Missile Paralyze Surround Paralyze Missile Paralyze
Teleport Speed Surround Speed Teleport
Missile Heal Surround Damage
Missile Damage Surround Heal
Missile Dispel Disrupt Disrupt Disrupt Damage Damage ...
Continuous Vivify Heal Heal Heal
Missile Vivify Heal Regeneration Speed Antimage Make-Weapon Teleport
Missile Forward Missile Damage - (Shoots through walls/furniture!)
Missile Missile Damage - (Shoots through characters/monsters!)
Continuous Teleport
Continuous Speed

and for the ultimate in 'nukes'..

Surround Missile Damage Damage Damage Damage Surround Damage Damage Damage
Damage Missile Damage Damage Damage Damage!

See the 'Spells for Objects' list in APPENDIX A for further suggestions.

At the start of the game, obvious choices for spells are quite limited and a good selection would be:

Missile Damage
Missile Damage Damage
Healing
Missile Healing

You could even experiment with the more esoteric spells

Missile Damage Missile Healing
or Missile Healing Missile Damage
or Missile Damage Missile Damage

Just remember that if you run out of ingredients you will be without spells until you collect enough gold to buy more. Don't hit a monster on it's last legs with a quadruple damage when a single would kill it just as effectively since you'll just end up running out of Brimstone. Once you're rich, of course, then it's a case of "who cares" until you realise just how far away the dungeon exit really is and that your favourite 'nuke' uses a dozen or more ingredients!

Learn where your most-used spells are in your spellbook so that you can cast them from the keyboard in an emergency. Not only does this avoid fumbling for the "Cast Spell" icon but it will automatically select the Runemaster as party leader.

Spells play a big part in banner encounters at low level. The leaders of any enemy banner are protected with Antimage and are enhanced with Speed. Hitting each of them with Dispel makes the whole encounter a lot easier. Similarly you may find that some monsters aren't taking any damage from your Damage spells. The most likely reason is that they are protected and, again, Dispel is the obvious solution. Dispel also deals quite effectively with teleporting monsters and will remove any continuous spell effects.

Try to have variety in your spells. For example, the two spells

Missile Dispel Disrupt Disrupt Disrupt Damage
Missile Dispel Paralyze

are quite different but have practically the same effect - the monster is no longer a threat. The first will kill almost anything and the second will paralyze almost anything until you can chop it up. The benefit of having both is that when you have run out of Brimstone you can still be using your Mandrake and the Runemaster stays in the game.

APPENDIX G – Bardish Melodies

Bardish Melody	Effect	Musical note colour
The Thief of Dolik Pass	Dexterity	Gold
Warriors Awakening	Strength	Light Green
The Ballad of Eleanor	Dodge Ability	Brown
Kijam's Litany	Constitution	White
The Smithy Song	Armour Class	Grey
March of the Bold Ones	Regeneration	Green
Adieu Sweet Dullard	Intelligence	Blue
Dance of the Faery Queen	Speed	Light Blue

It is often difficult to decide which song to play at any particular time:

The Thief of Dolik Pass only has use during combat. The extra dexterity will boost both attack and defence factors. The song thus gives improved combat accuracy while helping the party to dodge.

Warriors Awakening only has use during combat. The extra strength will boost not only attack factors but also damage done when hitting. This is the best combat spell when the party is confident of the quality of its armour or its ability to heal or regenerate quickly. The Troubadour can get quite an experience boost from using this spell simply due to the extra damage he will do.

The Ballad of Eleanor is, of course, in competition with 'The Smithy Song' for party protection. Having a better defence factor (dodge ability) will make a character harder to hit but having better AC will have the same end result of reducing the damage taken. Rather than go into the game mechanics I'll just suggest that you try each of them and see which is most effective at any particular stage of the game. They are both pretty effective.

Kijam's Litany is only useful when you are likely to be hit by Disrupt, Damage or Paralyze. In each case it will reduce the effectiveness of the spell; whether to reduce the damage incurred or the amount of time spent paralysed. It will not help to play the song once you have been paralysed to try and snap out quicker, the song must have been active when hit.

It's such a shame that the Guildmasters don't allow singing while attempting to gain experience levels as extra constitution will give extra hit points. They do, however, allow a character to wear a Sun Amulet or to equip any other item of constitution boost.

The Smithy Song - see 'The Ballad of Eleanor' above. There are stages of the game when the party's only real chance of surviving hand-to-hand combat is to play one of these two protection songs.

March of the Bold Ones is always useful. To the Troubadour this song is almost as good as a Regeneration spell and still very effective for the rest of the party. During the dungeon in Treihadwyl you should keep this song constantly active and its use is recommended whenever you finish a combat in need of healing.

Adieu Sweet Dullard can save your needing to put so many damage runes into your damage spells as extra Int. will make your spells more effective. Monsters damaged will be damaged more and paralysis will last longer, etc. A time when it is strongly recommended to play a few bars of this song is when about to use an item or spell to Vivify a character in the dungeon.

Having a stronger Vivify spell will resurrect a character with more luck, to a maximum of 16. To get maximum Int. boost, the character can use a Cloud Amulet, use the Ancient Staff and be listening to this song. You also get extra effect, of course, from Surround components in a spell so that using Surround-Vivify is more effective than Missile-Vivify and using Surround-Missile-Surround-Vivify is the most effective as the Vivify comes after two Surround components - it's just a little bit harder to hit the bones with the spell, though.

Dance of the Faery Queen can make characters more responsive during combat and can even help you pick up lots of gold quickly. The song is of little use once you start making extensive use of the Speed rune. The Cloud Boots item will also boost speed. Note that there is little if any extra benefit in extra speed once the value of the attribute reaches thirty two.

APPENDIX H - Reviews

"Wow! What an absolutely smashing game." ST Action - 93%

"...Legend is something for which I can happily throw away the review rulebook and state, right here, right now, that it's a must, must buy. Why? Because it's such an utterly fabulous thing, that's why." Amiga Power - 91%

"Thoroughly recommended. Get it and see why." ST Format - 89%

"The game runs fast, looks amazing and plays well. Adventure fans - don't miss it." Amiga Action - 91%

"An excellent game which deserves to do well." Amiga Format - 88%

...and that's it. Well, until WORLDS OF LEGEND: SON OF THE EMPIRE anyway...

LEGEND



Mindscape International Limited
Priority House, Charles Avenue, Maltings Park
Burgess Hill, West Sussex RH15 9PQ

Telephone: 0444 246333
Fax: 0444 248996



5018247711219

BO 200006