

# WING COMMANDER™

The 3-D Space Combat Simulator

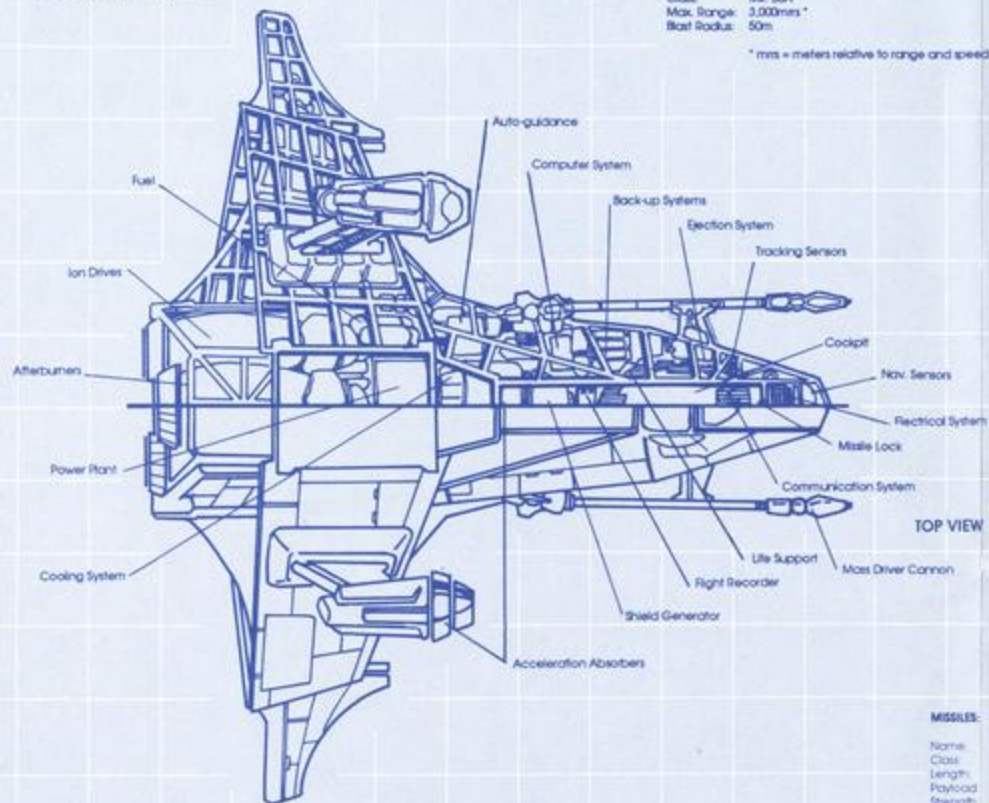

TOP VIEW

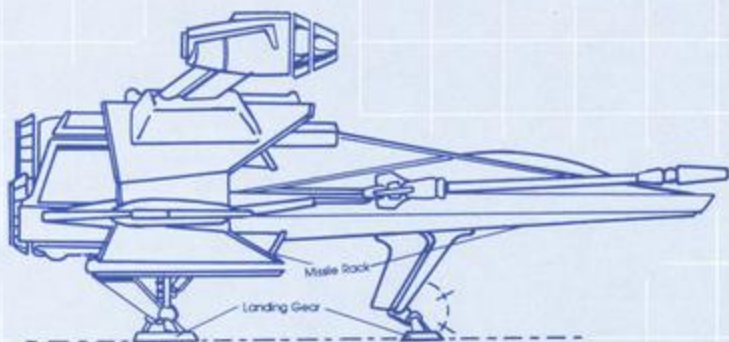

SIDE VIEW

## GUNS:

Name: Mass Driver Cannon  
 Class: Mk. 30A  
 Max. Range: 3,000mms \*  
 Blast Radius: 50m

\* mms = meters relative to range and speed

## MISILES:

Name: Dart DF  
 Class: Dumb-Fire  
 Length: 2.5m  
 Payload: 10,000 ESK  
 Strength: 11,000 ESK  
 Blast Radius: 50m  
 Max. Range: 10,000m  
 Eff. Range: 2,000m  
 Velocity: 900 kps  
 Max. Yaw: 10 DPS  
 Max. Pitch: 10 DPS  
 Max. Roll: 10 DPS



Name: Javelin HS  
 Class: Heat-Seeking  
 Length: 2m  
 Payload: 10,500 ESK  
 Strength: 10,500 ESK  
 Blast Radius: 50m  
 Max. Range: 9,000m  
 Eff. Range: 6,000m  
 Velocity: 850 kps  
 Max. Yaw: 10 DPS  
 Max. Pitch: 10 DPS  
 Max. Roll: 10 DPS

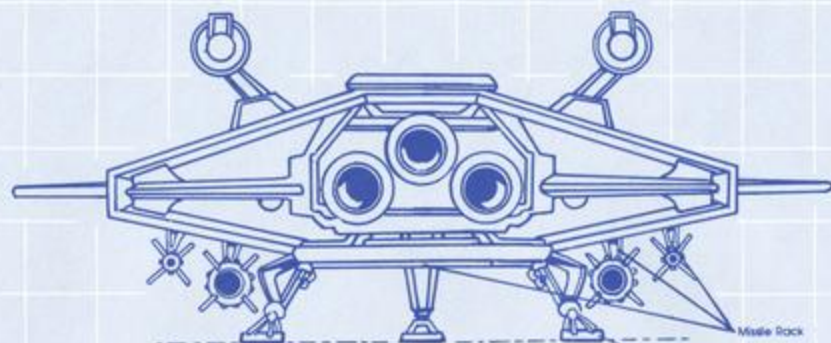

BACK VIEW

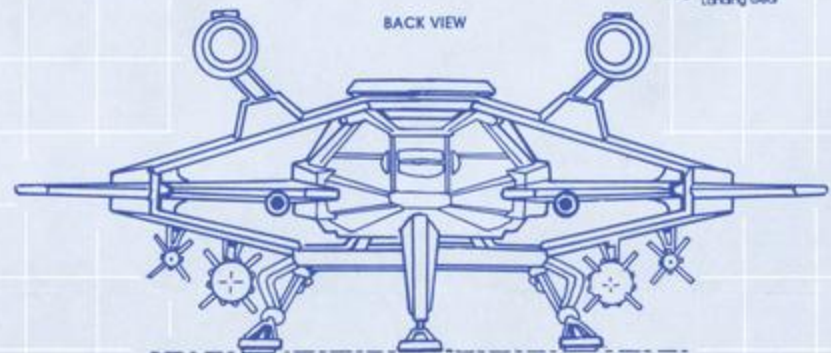

FRONT VIEW

## Scimitar

**Class:** Medium Fighter

**Length:** 25 meters

**Maximum Velocity:** 360 kps

**Acceleration:** Good

**Maximum Pitch:** 6 dps

**Ship's Weapons:** Gatling Mass Driver Cannon (2), Dumb-Fire Missiles (2), Heat-Seeking Missiles (3).

**Ship's Armor:** Fore Shield: 4 cm equivalent; Aft Shield: 4 cm equivalent; Front: 6 cm; Right: 5 cm; Left: 5 cm; Rear: 6 cm.

**Aerospace Engineering:**

**ORIGIN™**  
 Wing Commander & its Modifiers © ORIGIN Systems, Inc.  
 Copyright © 1992, ORIGIN Systems, Inc.



# WING COMMANDER™

The 3-D Space Combat Simulator

## GUNS

Name: Neutron Gun  
Class: Mk. 40F  
Max. Range: 2,500mms \*  
Blast Radius: 50m

\* mms = meters relative to range and speed

Name: Laser Cannon  
Class: Mk. 25  
Max. Range: 4,800mms \*  
Blast Radius: 50m

\* mms = meters relative to range and speed

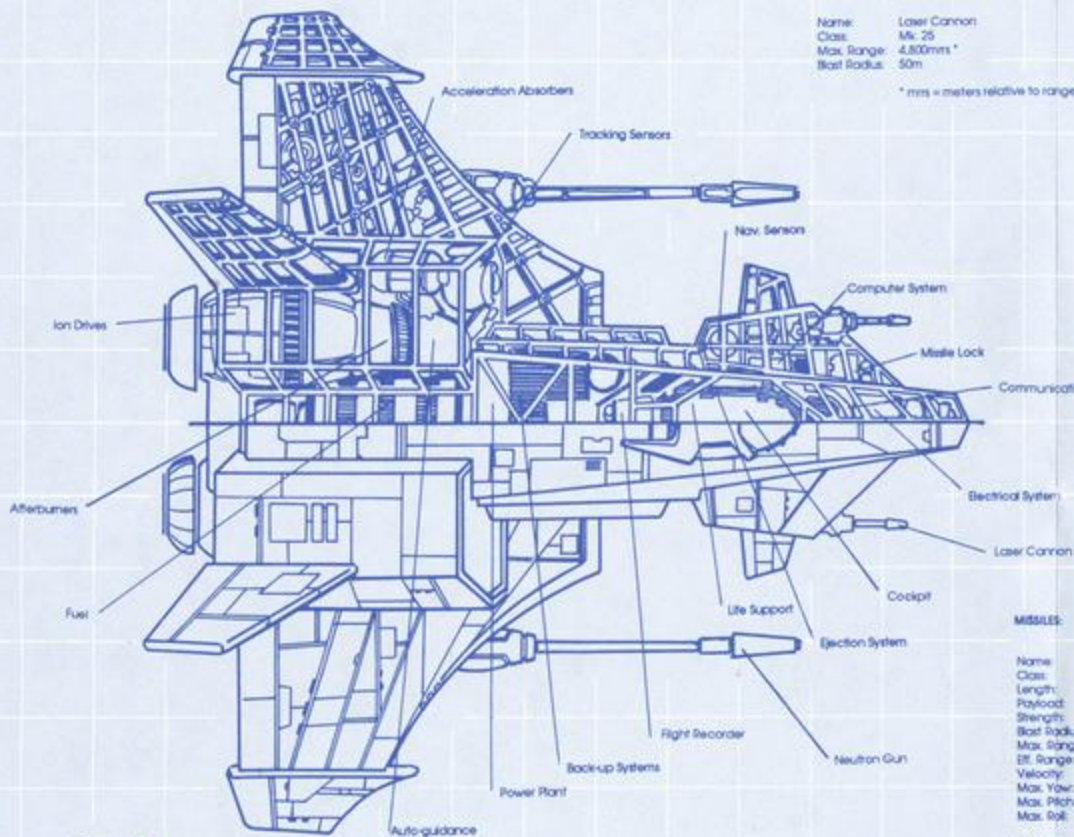

TOP VIEW

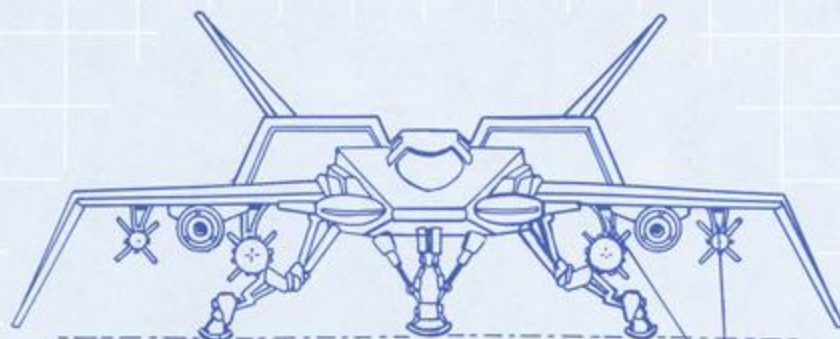

FRONT VIEW

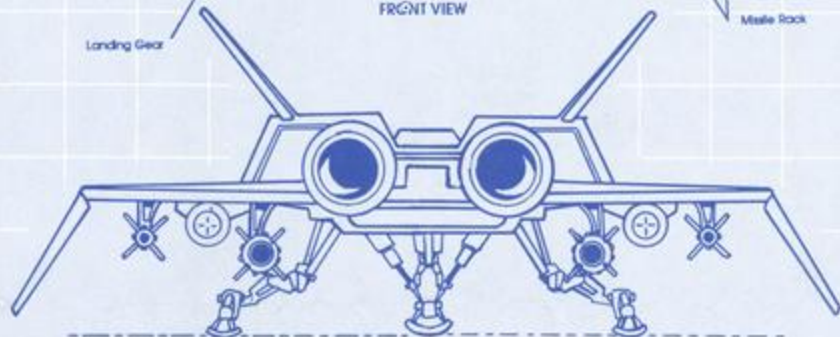

BACK VIEW

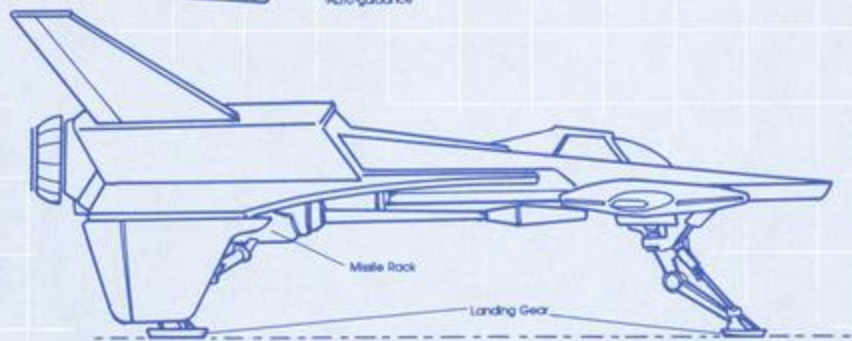

SIDE VIEW

## MISSILES:

Name: Dart Of Dumb-Fire  
Class: Budum PEW 36  
Length: 2.6m  
Payload: 11,000 ESK  
Strength: 50m  
Blast Radius: 10,000m  
Max. Range: 2,000m  
Eff. Range: 900 kps  
Velocity: 10 DPS  
Max. Yaw: 10 DPS  
Max. Pitch: 10 DPS  
Max. Roll: 10 DPS



Name: Spiculum IR Image Recognition  
Class: Budum PEW 36  
Length: 2.2m  
Payload: 9,500 ESK  
Strength: 50m  
Blast Radius: 8,000m  
Max. Range: 5,000m  
Eff. Range: 800 kps  
Velocity: 10 DPS  
Max. Yaw: 10 DPS  
Max. Pitch: 10 DPS  
Max. Roll: 10 DPS

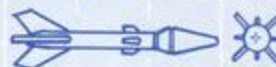

Name: Plum FF Friend or Foe  
Class: Budum PEW 36  
Length: 2.2m  
Payload: 9,500 ESK  
Strength: 50m  
Blast Radius: 12,000m  
Max. Range: 8,000m  
Eff. Range: 800 kps  
Velocity: 10 DPS  
Max. Yaw: 10 DPS  
Max. Pitch: 10 DPS  
Max. Roll: 10 DPS

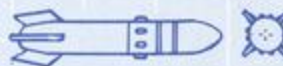

## Rapier

Class: Medium Fighter

Length: 24 meters  
Maximum Velocity: 450 kps  
Acceleration: Excellent  
Maximum Pitch: 10 dps  
Maximum Roll: 10 dps

Mass: 13.5 tonnes  
Cruise Velocity: 250 kps  
Maximum Yaw: 10 dps  
Maximum Roll: 10 dps

Ship's Weapons: Laser Cannon (2), Neutron Guns (2), Dumb-Fire Missiles (2), Spiculum IR (Image-Recognition) Missile, Plum FF (Friend or Foe) Missiles (2).

Ship's Armor: Fore Shield: 7 cm equivalent; Aft Shield: 7 cm equivalent. Front: 5 cm; Right: 3 cm; Left: 3 cm; Rear: 4 cm.

Aerospace Engineering:



Wing Commander is a trademark of ORIGIN Systems, Inc. Copyright © 1993 ORIGIN Systems, Inc.



## GUNS

Name: Laser Cannon  
 Class: Mk. 25  
 Max. Range: 4,800mms\*  
 Blast Radius: 50m

\* mms = meters relative to range and speed

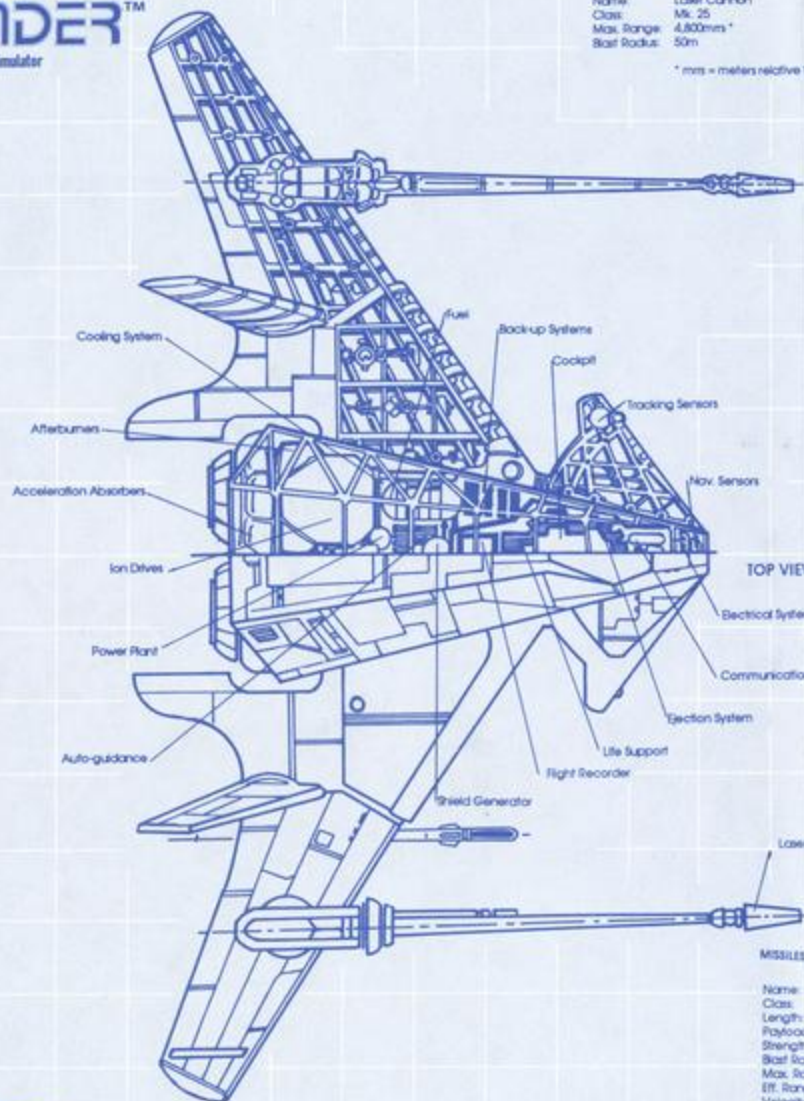

TOP VIEW

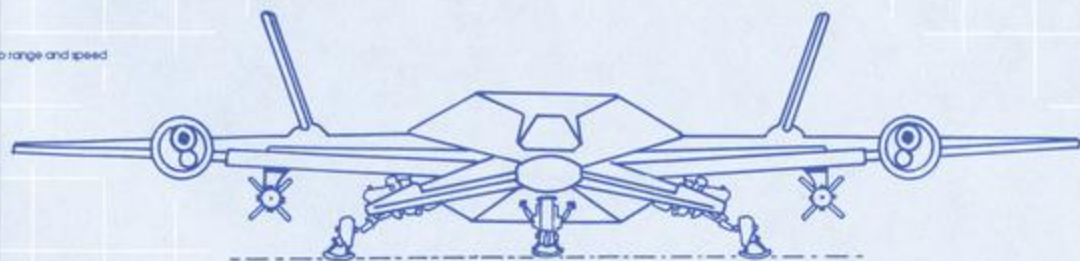

FRONT VIEW



BACK VIEW

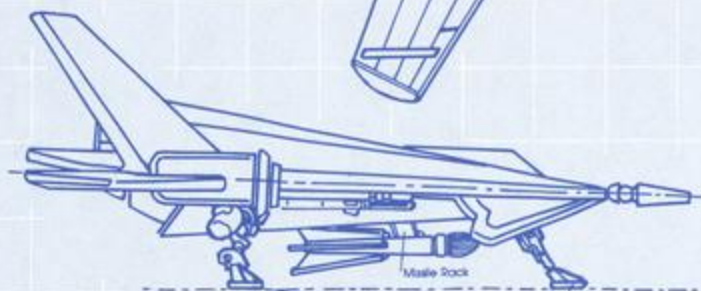

SIDE VIEW

Landing Gear

## MISSILES

Name: Dart DF  
 Class: Dumb-Fire  
 Length: 2.0m  
 Payload: 11,000 ESK  
 Strength: 50m  
 Blast Radius: 10,000m  
 Max. Range: 2,000m  
 Velocity: 900 KPS  
 Max. Yaw: 10 DPS  
 Max. Pitch: 10 DPS  
 Max. Roll: 10 DPS



Name: Javelin HS  
 Class: Heat-Seeking  
 Length: 2m  
 Payload: 10,500 ESK  
 Strength: 50m  
 Blast Radius: 6,000m  
 Max. Range: 4,000m  
 Velocity: 800 KPS  
 Max. Yaw: 10 DPS  
 Max. Pitch: 10 DPS  
 Max. Roll: 10 DPS

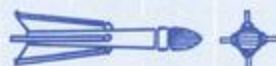

## Hornet

**Class:** Light Fighter  
**Length:** 20 meters  
**Maximum Velocity:** 420 kps  
**Acceleration:** Good  
**Maximum Pitch:** 9 dps  
**Ship's Weapons:** Laser Cannon (2), Dumb-Fire Missiles (2), Heat-Seeking Missile.  
**Ship's Armor:** Fore Shield: 3 cm equivalent; Aft Shield: 3 cm equivalent. Front: 3 cm; Right: 3 cm; Left: 3 cm; Rear: 3 cm.

Aerospace Engineering:



# WING COMMANDER™

The 3-D Space Combat Simulator

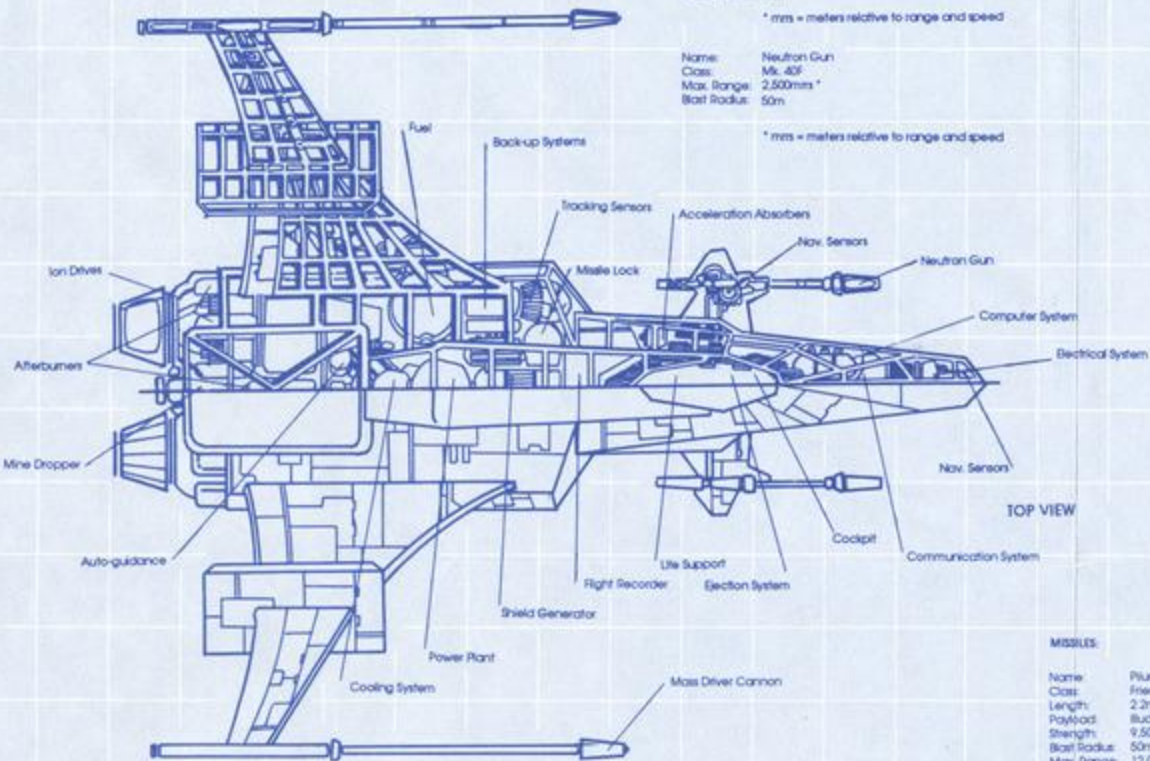

TOP VIEW

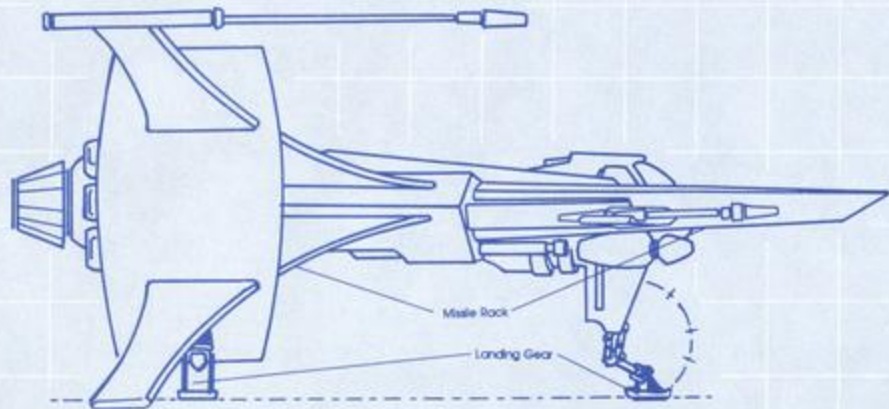

SIDE VIEW

**GUNS:**

Name: Mass Driver Cannon  
 Class: Mk. 30A  
 Max. Range: 3,000ms \*  
 Blast Radius: 50m  
 \* ms = meters relative to range and speed

Name: Neutron Gun  
 Class: Mk. 40F  
 Max. Range: 2,500ms \*  
 Blast Radius: 50m  
 \* ms = meters relative to range and speed

**MISSILES:**

Name: Pilum FF  
 Class: Friend or Foe  
 Length: 2.2m  
 Payload: 8xudum PEW 36  
 Strength: 9,500 ESK  
 Blast Radius: 50m  
 Max. Range: 12,000m  
 Eff. Range: 8,000m  
 Velocity: 800 KPS  
 Max. Yaw: 10 DPS  
 Max. Pitch: 10 DPS  
 Max. Roll: 10 DPS

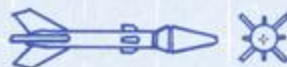

Name: Spiculum IR  
 Class: Image Recognition  
 Length: 2.2m  
 Payload: 8xudum PEW 36  
 Strength: 9,500 ESK  
 Blast Radius: 50m  
 Max. Range: 8,000m  
 Eff. Range: 6,000m  
 Velocity: 800 KPS  
 Max. Yaw: 10 DPS  
 Max. Pitch: 10 DPS  
 Max. Roll: 10 DPS

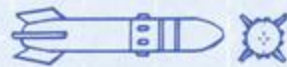

Name: Javelin HS  
 Class: Heat-Seeking  
 Length: 2m  
 Payload: 8xudum PEW 36  
 Strength: 10,500 ESK  
 Blast Radius: 50m  
 Max. Range: 9,000m  
 Eff. Range: 6,000m  
 Velocity: 800 KPS  
 Max. Yaw: 10 DPS  
 Max. Pitch: 10 DPS  
 Max. Roll: 10 DPS

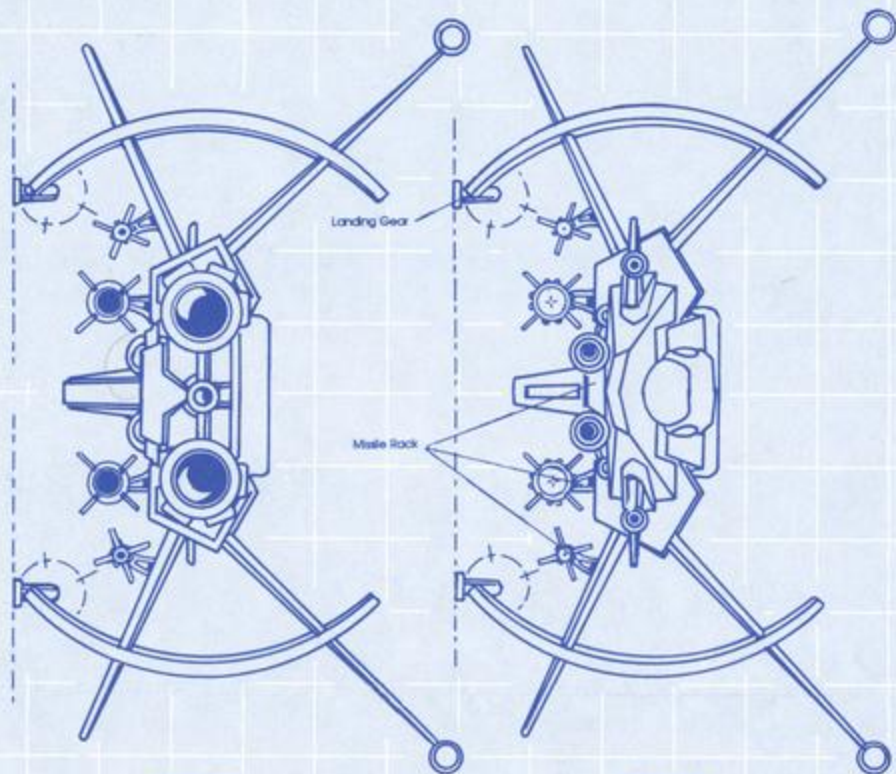

BACK VIEW

FRONT VIEW

## Raptor

**Class:** Heavy Fighter  
**Length:** 36 meters  
**Maximum Velocity:** 400 kps  
**Acceleration:** Good  
**Maximum Pitch:** 5 dps  
**Mass:** 20 tonnes  
**Cruise Velocity:** 250 kps  
**Maximum Yaw:** 6 dps  
**Maximum Roll:** 6 dps

**Ship's Weapons:** Neutron Guns (2), Gatling Mass Driver Cannon (2), Heat-Seeking Missiles (2), Spiculum IR (Image Recognition) Missiles (2), Pilum FF (Friend or Foe) Missile, Porcupine Space Mine.

**Ship's Armor:** Fore Shield: 7 cm equivalent; Aft Shield: 7 cm equivalent. Front: 8 cm; Right: 6 cm; Left: 6 cm; Rear: 8 cm.

Aerospace Engineering:





**This was brought to you**

**from the archives of**

**<http://retro-commodore.eu>**