

COUNTDOWN TO DOOMSDAY

LOG BOOK



STRATEGIC SIMULATIONS, INC.®

Questions or Problems?

Our main business number is (408) 737-6800. If you encounter disk or system related problems you can call our Technical Support Staff at (408) 737-6850 between 11 a.m. and 5 p.m., Pacific Time, Monday through Friday. **NO GAME PLAYING HINTS WILL BE GIVEN THROUGH THIS NUMBER.** If you need hints, call our Hint Line at (408) 737-6810. Recorded hints are available 24 hours a day, 7 days a week. If you don't hear the information you need, please write to us at Hints, Strategic Simulations, Inc., 675 Almanor Avenue, Suite 201, Sunnyvale, CA 94086 (include a stamped self-addressed envelope for quick reply.)

IBM COMPATIBLE COMPUTER INFORMATION:

If you own an IBM compatible computer we suggest that you consult with our Technical Support Staff at (408) 737-6850 any workday between the hours of 11 a.m. and 5 p.m., Pacific Time, to see if an SSI game you're considering purchasing is compatible with your computer. If we have insufficient data to determine compatibility, you may wish to purchase the game and test for compatibility yourself. If the game proves to be incompatible, you may return it within 14 days with your dated receipt and we will refund your money. Or, if you return the game within 30 days, you may exchange the game for another.

TABLE OF CONTENTS

Introduction	1
The Team Assembles	2
Characters and Teams	2
Additional Character Attributes	3
Character Races	4
Careers	5
Skills	7
Assembling a Team	10
Non-Player Characters (NPCs)	11
Money	11
Combat	11
Rocketships and Space Travel	14
Space Combat	17
Gear	19
Robots, Gennies and Other Opponents	21
Log Entries	23
Appendix	39
Racial Attribute Modifiers Table	39
Allowable Careers by Race Table	39
Strength Modifier Table	39
Dexterity Modifier Table	39
Constitution Modifier Table	39
Rocketjock Level Advancement Table	40
Warrior Level Advancement Table	40
Engineer Level Advancement Table	40
Rogue Level Advancement Table	40
Medic Level Advancement Table	40
Armor Class	40
Weapons Table	40
Skills Table	40
Glossary of Game Terms	41
Credits	43

◆ INTRODUCTION

1990-2050

Remnants of the old-time Soviet hardliners launch the space weapons platform: Masterlink. U.S. strategists send the American ace Anthony “Buck” Rogers to destroy Masterlink. Buck is sent up in an experimental spaceplane outfitted with a new cryogenic system for high altitude ejection. Masterlink is destroyed, but Buck Rogers’ plane is heavily damaged and his frozen body floats in space.

When Masterlink is destroyed, the Soviet extremists fire a salvo of ballistic missiles at the U.S. The resulting conflict enters history books as the “Last Gasp War.” World governments look in horror at the insane danger of escalating arms races and maintaining nuclear arsenals. Governments around the globe disassemble their war machines and power shifts from the national governments to large international alliances, such as the Russo-American Mercantile (RAM), the Euro-Bloc faction, and the Indo-Asian Consortium.

2051-2100

The System States Alliance forms to represent the three big power blocs and fringe Earth nations to help ensure the survival of a depleted and polluted Earth.

Nuclear fusion propulsion technology allows mankind to move out into the solar system. The System States Alliance forms an organized effort to exploit the nearby planets. RAM, having the most clout, grabs rights to Mars, while Luna goes to the Euro-Bloc, and the Indo-Asians take Venus. Initial interest in the planets is for resources. True colonization is slow at first, as mankind both adapts to alien environments and adapts the environments to mankind.

2101-2400

Trips to the planets become commonplace, and terraforming technology has transformed the surfaces of Mars and Venus to become more habitable for humans. Genetic engineering skills develop new life forms, called Gennies, that can be tailored to nearly any environment or function.

In 2275 RAM, groaning under an increasingly repressive Earth government, rebels. Venus signs a nonaggression pact with Mars, and ten years of war follow. Earth falls into barbarism with her major population centers left in ruins, and cut off from much needed extraterrestrial resources. At the end of the war, RAM completely dominates the remains of old Earth.

In 2310 refugees from Earth, and others who are discontent under RAM domination, begin a crash program to colonize Mercury. Asteroids are moved into orbit around the planet, and moveable cities are built on the surface. Mercury develops an economy based on mining and solar power.

2401-2455

Mars and Venus, once forbidding alien wastes, have been terraformed and now support populations in the millions. Bases have been established on Mercury and Luna. Colonies float in the edges of the Jupiter gas clouds and cities have been carved out of asteroids.

RAM rules old Earth with cruel efficiency and an iron hand, its brutal Terrine combat gennies roam and enforce the planet’s exploitation.

A daring band of Rebels called the New Earth Organization (NEO) is formed to combat RAM domination.

2456

The figure of Buck Rogers has been elevated to nearly mythical status by media hype — he has become a symbol as the last

martyr of old Earth's foolish political struggle. In a strange twist of fate Buck Rogers — the myth — is recovered alive from his frozen sleep!

With his tactical genius and fearless daring, Buck Rogers joins NEO in its battle against RAM.

NEO, and Buck Rogers, form a dangerous plan to subvert RAM control of the Earth. The cornerstone of RAM's dominance of the planet is "Gauntlet", an orbital weapons platform originally constructed by the old Systems States Alliance. Gauntlet had been designed to act as a watchdog against nuclear weapons. Under RAM administration, the station was upgraded to both watch the subservient Earth and completely control all traffic to and from the planet.

Buck steals a squadron of RAM's latest spacefighters, a squadron slated for Gauntlet's defensive force, and attacks the station. The surprise attack is a success. Without Gauntlet, Simund Holzerhein, the head of RAM, decides that overt control of Earth is too expensive and orders RAM troops off of the planet. The mood on Earth and in NEO is a combination of excitement and dread. The victory seems easy... too easy.

2456(Now)

Earth is under the control of NEO now, but the shadow of RAM is still present. Occasional attacks by RAM military are explained away as "acts of overanxious officers" and "unfortunate lapses of judgment." NEO scrambles to rebuild a shattered planet and build the forces required to fend off the RAM attack it feels is inevitable.

◆ THE TEAM ASSEMBLES

"Buck Rogers!" The name is everywhere. "Buck Rogers and NEO victory at Gauntlet — Vid at eleven." The Video Network News, people talking on the streets of old Earth, even in the furthest asteroid outposts — Buck Rogers and NEO are everywhere.

There is a feeling of hope now. After years of domination, RAM no longer holds old Earth, and NEO is finally able to make a real stand against the corporate behemoth. Victories, real and exaggerated, boost NEO confidence daily.

NEO ranks are swelling with new recruits — young people who never before felt they could make a difference. Your team is assembled from those ranks. Each member has made his or her way to Chicagorg with plans to join the war against RAM supremacy. Each has visions of great victories, glory, and lasting fame — like Buck Rogers....

◆ CHARACTERS AND TEAMS

To play Countdown to Doomsday, you must make characters and band them together into a team. The team must have a variety of talents and skills to survive and finally succeed. The following sections describe everything that goes into making a character and assembling your team.

Character Ability Scores

Every character has seven randomly-generated ability scores that define the person. The scores describe the character's strength, intelligence, and so on. The base value for each ability is from 3 (low) to 18 (high). Each race has ability modifiers that are automatically factored in when the character is generated. For example, Martians receive a -1 modifier to strength, but they get a +1 bonus modifier to their dexterity. The following describes each ability.

Strength (STR) measures physical power and indicates a character's endurance, stamina, and muscle bulk. Strong characters can carry more weight in equipment without becoming encumbered, and they have combat bonuses when fighting with melee weapons (swords, mono knives, etc).

Dexterity (DEX) measures hand-eye coordination and agility, as well as reaction speed and other reflexes. High dexterity gives characters bonuses to avoid being hit during combat, determines how fast they react, and how well they can fire ranged weapons (laser rifles, bolt guns, etc) or fly a rocketship.

Constitution (CON) measures physical toughness and resistance to pain and hardship. High constitution increases the amount of damage a character can withstand before dying.

Intelligence (INT) measures reasoning ability, memory (to some extent), and general wit and cleverness. High intelligence is required for most careers — in the twenty-fifth century, stupidity kills.

Wisdom (WIS) measures common sense and ability to understand the ways of the world. This is the skill that both aids Medics in making sound treatments, and keeps Rogues from fleecing the wrong victims. High wisdom gives bonuses to such skills as Tracking and Planetary Survival.

Charisma (CHA) measures persuasiveness and how well others react to a character. Leaders are marked by high charisma, and this ability is valuable when dealing with strangers. High charisma gives bonuses to such skills as Intimidation and Acting.

Tech (TCH) is short for Technical Knowhow, and is a special mix of intelligence and wisdom that measures affinity for machinery and equipment. High tech scores improve such valuable skills as Jury Rigging and First Aid.

More on Abilities

The STR, CON, and DEX bonuses tables start in the appendix on page 39. Ability scores can affect skills; this is described under **Skills and Abilities** on page 7.

◆ ADDITIONAL CHARACTER ATTRIBUTES

Characters have three attributes that change during the game: Experience Points, Level, and Hit Points.

Experience Points (EXP) measure what a character has learned. EXP are earned by winning battles, finding money, and completing parts of the adventure. Characters with enough EXP may advance in levels. The **Level Advancement Tables** begin in the appendix on page 40.

Level measures a character's career advancement. Characters gain valuable skill points and combat proficiency when they advance in level. When characters have sufficient EXP to go up a level, they must go to the Training Center to receive the additional instruction for advancement.

Example: A second level Warrior with 4,000 EXP can train and become third level.

No matter how many EXP a character has, only one level can be gained per training session. A character with sufficient EXP to gain two or more levels can train, advance one level, and then lose all EXP in excess of one point less than is required to advance another level.

Example: A second level Warrior with 16,500 EXP (enough to advance to fourth level) would train, advance to third level, and be left with 7,999 EXP (8,000 would be fourth level). The character could then easily gain the one point needed to advance and then train again quickly.

Characters start the adventure at second level and can advance to eighth level.

Hit Points (HP) measure how much damage a character can withstand before becoming unconscious or dead. Characters gain between 1-6 and 1-10 HP per level depending on their career.

More on Attributes

The **Level Advancement Tables** showing EXP requirements for all careers begin on page 40.

◆ CHARACTER RACES

Team members can be any of six races — four human types or two gennies. Terrans, Martians, Venusians, and Mercurians are all, in spite of some genetic engineering, considered humans. Martian Desert Runners and Tinkers are gennies that have been bred to include non-human characteristics with the basic human genotypes. Each race has unique modifiers to basic attributes, and some careers are limited to certain races. The following section describes each of the races.

Terrans are the last of the unengineered humans in the solar system. While the other civilized races have undergone genetic adaptation to suit new planets and environments, the human population on old Earth takes pride in their pure strain. Suffering under the yoke of RAM tyranny has taught the Terrans determination and patience.

Allowable Careers: All
Ability Modifiers: CON +1, WIS +1

Martians have developed under RAM auspices the oldest and most advanced civilization in the solar system. The Martians themselves tend to be proud to the point of arrogance. Because of the lower Martian gravity and oxygen content, Martians are slightly weaker than Terrans, but about average for other civilized races.

Allowable Careers: All
Ability Modifiers: STR -1, DEX +1, CON -1, WIS -1, CHA +1

Venusians are a divergent lot. Venus has three distinct cultures beneath its billowing atmosphere. The Aerostators float above the lands, and make their living primarily as tradesmen and herders. The ground-

dwelling Aphroditians are farmers, miners, and shrewd traders. The dominant culture on Venus is the theocratic Ishtarians. They control New Elysium, Venus' only major spaceport.

Allowable Careers: All
Ability Modifiers: DEX -1, CON +1, WIS +1, CHA -1

Mercurians are a unique and rough mixture of cultures. Originally, Mercury was the site of large solar energy collection stations called Mariposas. The Mercurian Sun Kings are descended from the original Mariposa owners, and are quite wealthy. The Sun Kings are renowned for decor that is both fabulously expensive and totally devoid of taste. The remaining three cultural groups on Mercury are descended from the refugees that fled to the planet to escape the turmoil in the rest of the solar system. The Miners inhabit large subterranean warrens shielded from the intense heat. The Musicians are the Mercurian merchant class. The Desert Dancers live on the planet's surface, continually following the shaded side of the planet.

Allowable Careers: All
Ability Modifiers: STR -1, DEX +1, CON +1

Tinkers were originally bioengineered to include attributes from small anthropoid species, such as lemurs and gibbons, to work in cramped spaces. They are very clever with tools and all manner of technology.

Allowable Careers: Engineer, Medic
Ability Modifiers: STR -2, DEX +3, CON -2, TECH +3

Desert Runners are one of the oldest of the bioengineered races, and are bred for the savage Martian surface. Their original purpose was to care for the large herds of



animals that were seeded onto the planet during the late stages of terraforming. The Desert Runner engineering adds a mix of canine and feline attributes to the basic homo sapien stock. They can run long distances on all fours, and fight viciously with their retractable claws. Desert Runner's claws allow them to do an extra point of damage if they fight bare-handed.

Allowable Careers: Rocketjock, Warrior, Engineer

Ability Modifiers: STR +2, DEX +2, CON +1, CHA -1

More on Races

There are several tables summarizing racial attribute modifiers and allowable careers in the appendix starting on page 39.

◆ CAREERS

There are five careers for characters to choose from in Buck Rogers, and each career has a unique set of skills associated with it. Minimum attributes are required for each career choice. For example, Medic characters must have minimum scores of 12 in dexterity, intelligence, and wisdom. When creating characters, the career is selected first, then the computer will generate ability scores to fit. Some careers are limited to select races. Rogues, for example, can only be human. Each career has a set of Career Skills that the character learns while training for a given occupation.

The following describes each career.

Rocketjocks have what one twentieth century author called "the right stuff." They are only truly at home when they are clutching the controls of some type of space vehicle. They pride themselves in their ability to out fly and out romance anybody in the galaxy, and too often they're right.

Special Ability: Rocketjocks receive a 10% bonus to all piloting skills.

Ability Score Requirements: DEX 13, INT 11, CHA 12

Eligible Races: Terran, Martian, Venusian, Mercurian, Desert Runner

Career Skills:

- Drive Jet Car
- Drive Ground Car
- Maneuver in Zero G
- Notice
- Pilot Fixed Wing
- Pilot Rocket
- Pilot Rotorwing
- Use Jet Pack

Warriors dedicate their lives to mastering the skills of combat. Even with the development of fantastic new weapon technologies, battles are still won and lost by men. Warriors train hard, and study strategy and leadership in addition to combat skills.

Special Abilities: Because of their rigorous training, Warriors receive bonuses to the amount of damage they can withstand. Warriors can also attack twice per round with their fists where other characters can only attack once. Warriors do one to three points of damage with their bare fists, where other classes only do one to two. Every second level (2nd, 4th, 6th...) Warriors also receive a specialization bonus to a weapon of their choice. Weapons specialization bonuses can only be a maximum of plus three per weapon.

Ability Score Requirements: STR 10, DEX 8, CON 10, INT 8

Eligible Races: Terran, Martian, Venusian, Mercurian, Desert Runner

Career Skills:

- Battle Tactics
- Demolitions
- Leadership
- Maneuver in Zero G
- Move Silently
- Notice
- Repair Weapon
- Use Jet Pack

Engineers are what hold the world together — without them the artifices of technical civilization would crumble. Engineers aren't as cocky or flashy as Rocketjocks, but they have a similar arrogant pride in their abilities. Engineers love machines and fine workmanship. They prefer the company of a cranky ship's power plant to the hubbub of a port bar.

Special Abilities: None

Ability Score Requirements: STR 10, CON 12, INT 8, TECH 13

Eligible Races: Terran, Martian, Venusian, Mercurian, Tinker, Desert Runner

Career Skills:

- Jury Rig
- Maneuver in Zero G
- Notice
- Repair Electrical
- Repair Life Support
- Repair Mechanical
- Repair Nuclear Engine
- Repair Rocket Hull

Rogues live by wit, cunning, and oftentimes, the misfortune of others. Rogues have talents for fast talking, and bypassing pesky security systems. Because of the nature of their work, and their ability to make lasting enemies, Rogues who live to any noticeable age tend to have very fast reflexes.

Special Abilities: Rogues receive a 10% bonus to all Career Skills.

Ability Score Requirements: DEX 13, INT 8, WIS 9, CHA 13

Eligible Races: Terran, Martian, Venusian, Mercurian

Career Skills:

- Bypass Security
- Climb
- Fast Talk/
Convince
- Hide in Shadows
- Move Silently
- Notice
- Open Lock
- Pick Pocket



Medics seem to be very popular whenever a team sees any action. When the Warrior develops work-related injuries (usually laser holes), or the engineer gets too close to an engine that blows up, the Medic puts them back together. The advancements of medical technology will never remove the need for the human touch in healing. Medics learn skills such as treating wounds, counteracting poisons, and operating ship-board Medical Centers.

Special Abilities: Medic Career Skills can ONLY be learned by Medics — all skills from the other careers can be learned by anyone (although without career bonuses).

Ability Score Requirements: DEX 12, INT 12, WIS 12

Eligible Races: Terran, Martian, Venusian, Mercurian, Tinker

Career Skills:

- Diagnose
- Life Suspension Technician
- Treat Critical Wounds
- Treat Disease
- Treat Light Wounds
- Treat Poisoning
- Treat Serious Wounds
- Treat Stun/Paralysis

More on Careers

The summary of careers allowable to each race is in the appendix on page 39. The **Career Skills** tables begin on page 5.

◆ SKILLS

Skills represent specific abilities of characters. For the Rocketjock, the ability to zig when he's supposed to zig, and zag when he's supposed to zag in a space battle is the skill called Pilot Rocket. There are two types of skills: Career Skills and General Skills. Career Skills are the types of things a character would learn while training for a job. General skills are extracurricular abilities that the character might find useful. Characters get points to allocate to skills. Because the player gets to choose where points go, each character develops uniquely.

Some commands in the game are only available to characters with the correct skills.

Example: The JURYRIG option only appears during space combat if a ship's system is damaged and the character has Jury Rig skill.

Assigning Points to Skills

Newly generated characters start at second level with 80 points to assign to eight different Career Skills, (they get 40 more points for each level gained). New characters may allocate 30 points to any single career skill, but no more than 15 points may be allocated at one time after that. There is no limit to how many points can be allocated to a Career Skill overall — only 80 points total can be allocated to any single General Skill.

New characters may choose a maximum of seven General Skills to start the game with. They can assign 40 points to these skills. With each new level gained characters can choose one additional skill, and assign 20

more points to any of their General Skills. So, choose the mix of skills wisely for your team characters. Career Skill points can only be assigned to Career Skills and not General Skills and vice versa.

Skills and Abilities

Each skill primarily uses one ability, and so most are listed by their primary ability requirement. Pilot Rocket, for example, is a dexterity skill, while Repair Rocket Hull is a tech skill. The exception to this are the Medic skills, which are only available to characters with that special career training. In addition to career bonuses, characters get Ability Bonuses added to their skills. The Ability Bonus is simply the character's score for the appropriate ability.

Example: A character with 15 points allocated to Use Jet Pack (a dexterity skill), and with a 17 dexterity, would have an effective skill of 32.

Skill Prerequisites

Some skills require minimum scores in other skills before points can be allocated to them.

Example: Jury Rig skill requires minimum scores of 10 in both Repair Mechanical and Repair Electrical.

Certain skills in the game are useful only as prerequisites for other skills.

Skill Checks

A Skill Check is used to determine whether a character can perform some action that requires a certain skill. For example, Medics make Skill Checks against their Treat Light Wounds skill to see if they can restore hit-points to injured characters after combat. A skill score represents a percentage chance

for success on a Skill Check. If a character has a 75 Jury Rig skill, then he has a 75% chance of successfully jury rigging an average problem. The chance for success changes if the situation is more or less difficult.

Unused Skills

A few of the listed skills are not actually used in Countdown to Doomsday. They have been included for use in sequel games. Unused skills are noted in the following section.

Skills Descriptions

Dexterity Skills:

Acrobatics is the skill of balancing, juggling, avoiding falling objects and other unusual feats of dexterity.

Climb is the skill of scaling anything from mountains to buildings without the use of ropes.

Drive Groundcar is the ability to use any type of small wheeled vehicle. This skill is not used in Countdown to Doomsday.

Drive Jetcar is the ability to use any type of small jet-propelled vehicle. This skill is not used in Countdown to Doomsday.

Hide in Shadows is the ability to use available cover, both shadows and terrain, to avoid detection.

Maneuver in Zero-G is the skill used to move and work in a gravity-free environment. This is a critical skill whenever fighting in a Zero-G situation. Characters who fail a Maneuver in Zero-G Skill Check receive a large penalty to their movement and ability to hit targets.

Move Silently is the ability to travel quietly, even through brush or over rocks and gravel. This skill is used when attempting to backstab during combat.

Pick Pocket is used to take small items from unsuspecting victims.

Pilot Fixed Wing Craft is the ability to fly jet or propeller-powered aircraft. This skill is not used in Countdown to Doomsday.

Pilot Rocket is required to operate any rocketship. This is the premiere skill of Rocketjocks.

Pilot Rotorwing Craft is the ability to fly helicopter-type aircraft. This skill is not used in Countdown to Doomsday.

Use Jet Pack is the skill to operate a personal jet pack. This skill can be used during combat if a character is outfitted with a jet pack.

Tech Skills:

Bypass Security is the skill to trace and disable electronic alarm systems.

Commo Operation is adeptness with communications equipment, including repair and operation.

Demolitions is the skill to use, place, and defuse explosive devices.

First Aid is the ability to perform minimal emergency medical treatment. Characters with First Aid are handy during combat to augment Medics.

Jury Rig is the very valuable skill to patch together damaged equipment. This skill can be a real lifesaver during space combat. Prerequisites are Repair Mechanical (10) and Repair Electrical (10).

Open Lock is the skill of picking mechanical locks. Electronic locks are covered under the Bypass Security skill.

Repair Electrical is the skill to maintain and repair electrical systems. This skill is used to make field repairs to a ship after combat.

Repair Life Support is the skill to maintain and repair life support systems. This skill is used to make field repairs to ships after combat. Prerequisites are Repair Mechanical (25) and Repair Electrical (30).

Repair Mechanical is the skill to maintain and repair mechanical equipment. This skill is used to make field repairs to ships after combat.

Repair Nuclear Engine is the skill to maintain and repair the nuclear engines found on rocketships. This skill is used to make field repairs to ships after combat. Prerequisite is Repair Mechanical (10).

Repair Rocket Hull is the skill required to patch up damaged rocketship hulls. This skill is used to make field repairs to ships after combat. Prerequisite is Repair Mechanical (10).

Repair Weapon is the skill to restore damaged weapons to service. This skill is used to make field repairs to ships after combat.

Sensor Operation is familiarity with the operation of sensor equipment and evaluation of sensor data. This skill is used to gather information about enemy ships and crew sizes during space combat.

Medic Skills:

Diagnose is the ability to determine the nature of an ailment or internal injury.

Life Suspension Tech is the skill to operate and diagnose potential malfunctions on life suspension equipment. This skill is not used in Countdown to Doomsday.

Treat Critical Wounds is the ability to deal with severe injuries. Prerequisite is Treat Serious Wounds (40).

Treat Disease is the ability to treat diagnosed diseases. Prerequisite is Diagnose

(25). This skill is not used in COUNTDOWN TO DOOMSDAY.

Treat Light Wounds is the ability to give field aid to minor injuries. This is similar to the general First Aid skill, and is valuable during combat.

Treat Poisoning is the knowledge of how to counteract diagnosed poisons. Prerequisite is Diagnose (15).

Treat Serious Wounds falls between Treat Light and Treat Critical Wounds. This skill is only used after combat. Prerequisite is Treat Light Wounds (30).

Treat Stun/Paralysis is a battlefield skill to treat battle induced shock from sonic stunners.

Intelligence Skills:

Astrogration is the ability to calculate courses, plot the movement of astronomical bodies, and to sight on stars. Astrogration is used to find specific locations while traveling in space. Prerequisites are Astronomy (20) and Mathematics (25).

Astronomy is a working knowledge of the planets, stars, and other astronomical bodies. Prerequisite Only.

Battle Tactics is the understanding of small-group combat tactics. If a character makes a Battle Tactics role at the start of an encounter, the whole team will receive combat bonuses because they are better able to act as a unit.

Disguise is skill in the use of makeup and costume to assume a new appearance.

Library Search is the skill to ferret information out of computer library systems.

Mathematics is the capability to perform complex mathematical operations and calculations. Prerequisite Only.

Mimic is the ability to copy the vocal patterns and sounds of others.

Navigation is the skill to calculate courses and effectively steer a rocketship on its trip. Prerequisites are Astronomy (15) and Mathematics (25).

Planetology is an understanding of the ecology, climate, geology, and hazards of planets.

Programming is the ability to program both planetside and shipboard computers. Prerequisite is Mathematics (10).

Charisma Skills:

Act is the ability to memorize and perform lines and to take on characterizations.

Befriend Animal is the skill to relate to animals and create some kind of rapport.

Distract is the ability to successfully act as a diversion or to direct a victim's attention.

Etiquette is an understanding of the rules and conventions of a culture. This is especially useful when patronizing the better class establishments on Outposts.

Fast Talk/Convince is the skill to flim-flam and get others to agree or accept.

Intimidate is the ability to create an aura of menace and danger. Successful intimidation during combat will cause enemies to be taken aback while they decide whether to fight or flee.

Leadership is the skill to give orders and see that they are carried out. Characters with Leadership skill can, if they make a difficult Skill Check, take control of NPCs during combat.

Sing is the ability to deliver a tune with a melodious and pleasing voice. This skill can come in handy in Outpost bars.

Wisdom Skills:

Notice is the skill of careful, trained, observation. Many times a character with high Notice skill will see things that other team members miss.

Planetary Survival is a working knowledge of how to survive wilderness conditions on a variety of planets. Prerequisite is Planetology (10).

Shadowing is the ability to follow people in urban areas without being discovered.

Tracking is the skill to follow tracks and signs in a wilderness environment.

◆ **ASSEMBLING A TEAM**

Assembling a strong and multi-talented team is the key to success in Countdown to Doomsday. The variety of careers and skills must be able to deal with the many perils and uncertainties of the twenty-fifth century.

Careers and Races Mix

Every team should have at least one Rocketjock, one Medic, and one Engineer. The remainder of the party can be a mix of careers. Take a look at the Racial Attribute Modifiers to select a good mix of races.

Skills Mix

Several skills are critical for the survival of the team. Medical and First Aid skills are used to patch up wounded team members. At least one character with Pilot Rocket is required to effectively control a rocketship. Characters with Engineering skills like Jury Rig are very useful during space combat. Maneuver in Zero-G is used every time the team fights in a null-gravity environment. Battle Tactics is very useful during fire-fights.

Other useful skills are: Leadership, Intimidate, Navigation, Astrogation, Sensor Operation, Demolitions, Use Jet Pack, and Move Silently.

◆ NON-PLAYER CHARACTERS (NPCs)

Non-player characters (NPCs) are the people the team meets during the adventure. Sometimes NPCs are threats that the team must deal with quickly. Other times NPCs may offer valuable information or even join the team for awhile.

NPCs that join the team generally fight under computer control. If any member of the team has Leadership skill, and makes a successful Skill Check at the start of a combat, then you may control the NPC for that battle.

Digital Personalities (Dps)

In the twenty-fifth century, computer technology has advanced to the point that fully aware, computer-based intelligences have evolved. These Digital Personalities can be either purely computer-generated or based on a living, or once living, mind. The latter are created by “mapping” the brainwave patterns and memories of a living person to create a software “clone” of the mind. A suffix of .DOS is added to the names of computer personalities for ease of identification.

◆ MONEY

Every planet in the solar system has its own currency system, but the Credit has been developed as the common unit of exchange. Bank accounts and interplanetary transactions, for example, are always handled in credits, on any planet. The most common form in which to carry money is negotiable “Credit Cards.” Each card has a coded strip that “remembers” how much it is worth. Purchases can be debited from the card value until it is valueless. Unlike twentieth century credit cards, these cards cannot be replaced if lost or stolen — they can be used by anyone who gets hold of the card.

◆ COMBAT

The team moved through the derelict rocketship carefully. Ulysses, one of the team’s two warriors was leading. He strained his senses, trying to pick up any sign of combat gennies or security robots. They had just moved cautiously around one corner into a new corridor when Ulysses heard the distinct whine of a laser firing circuit charging...

“Security robots ahead! Red, dump a grenade on ‘em. Doc and Ratchet hit ‘em with laser! Looks like it’s gonna hit the fan...”

Whether facing killer Terrine gennies or boarding space pirates you will find yourself in combat often in the twenty-fifth century.

Initiative

Each round of combat is divided into 10 segments. The segment a character or opponent acts in depends on his initiative number. This is a randomly generated number for each character and opponent. This random number is generated at the beginning of each combat round and is modified by dexterity bonuses or penalties and random factors (such as surprise) to arrive at the initiative number.

Sometimes a character will act in segment 10 of one round and segment 1 of the next, appearing to act twice in a row. This is especially common if you use the WAIT command. When the WAIT command is given, that character’s action will be delayed until segment 10.

Combat Ability

Each character’s ability in combat is defined by his THACØ, damage and AC.

AC

A character’s or opponent’s difficulty to be hit is represented by his Armor Class or AC. The lower the AC the harder it is to hit the target. AC is based on the armor a character is wearing and any dexterity bonus.

THACØ

THACØ represents ability to hit enemies in melee or with ranged fire. THACØ stands for To Hit Armor Class Ø. This is the number a character must 'roll' equal to or greater than to do damage on a target with an AC of Ø. The lower the THACØ the better the chance to hit the target.

Note: The generation of a random number is often referred to as a 'roll'. In determining if an attack is successful, the roll is a random number from 1 through 20.

An attack is successful if the random number is greater than or equal to the attacker's THACØ minus the target's AC. THACØ may be modified by range, terrain, and zero-G conditions, among other things.

Example:

A Warrior with a THACØ of 15 attacking an opponent with an AC of 3 would need to roll:

$$(THACØ 15) - (AC 3) = 12+$$

But to hit a opponent with an AC of -2 he would need to roll:

$$(THACØ 15) - (AC -2) = 17+$$

THACØ decreases (requires a lower number to hit an opponent) as a character's level increases. Great strength can help THACØ if the character is attacking with a melee weapon (sword, knife, etc).

Damage

When a hit is scored, the attacker does damage. Damage is the range of HP loss the attacker inflicts when he hits an opponent in combat. Damage depends on the attacker's weapon type and sometimes the attacker's strength (when using melee weapons).

Some opponents take only partial or no damage from certain weapon types. Robots, for example, are immune to such attacks as dazzle or gas grenades, while Venusian acid frogs are unaffected by fire.

Saving Throws

Whenever characters or opponents are poisoned, subjected to extremes of heat or cold, or certain types of weapons, the computer checks



to see if they make their Saving Throw. A successful save means that the target had some innate immunity to the poison, or was not hit full-force by the weapon effect. Generally a successful save will mean that the target was unaffected or damage that would otherwise be taken is halved.

Leadership Skill Check

When NPCs join the team, they will generally fight under computer control. If any member of the team has Leadership skill, and makes a successful Skill Check at the start of a battle, an NPC will be under manual control for that battle.

Battle Tactics Skill Check

The computer automatically makes a Battle Tactics Skill Check for any characters with the skill. If any character is successful, the entire team receives a plus one combat bonus because they are better able to act as a group.

Maneuver in Zero-G Skill Check

Whenever characters enter combat in null-gravity conditions, they must make a Maneuver in Zero-G Skill Check or become severely restricted. Characters that fail to make this roll receive a minus two combat penalty and their movement is reduced to three squares per round.

Combat Map

Combat takes place on a tactical map that is a detailed 3-D view of the map terrain that the team was in when combat began. This map is overlaid with an invisible square grid. As you move characters, you will notice that everything moves on the grid from square to square. Moving diagonally often costs more movement points than moving horizontally or vertically.

Terrain

When the laserbeams and rockets start flying, being able to duck behind cover becomes a big concern. There are three basic types of terrain: clear, hindering, and blocking. Clear terrain is just that, open and free of obstacles. Hindering terrain offers some cover from enemy weapons fire by making targets more difficult to hit, and slows movement. When traveling overland, hindering terrain might be bushes or low rocks. In outposts or civilized areas, hindering terrain would be objects like tables or computer terminals. Blocking terrain would be walls or trees — objects that cannot be moved or fired through at all.

Temporary Obstacles

Several weapons have effects that hinder combat: chaff, aerosol, and gas. Chaff clouds will cause missiles from rocket weapons to lose tracking as well as causing all types of explosive shields to detonate instantly when they hit the chaff. Aerosol clouds are designed to diffuse laserbeams. Gas clouds do not affect ranged combat, but anyone or thing that moves through a gas cloud without some kind of breathing apparatus must make a saving throw or become incapacitated.

Computer Control

The computer controls the actions of opponents, NPCs, and PCs set to computer control with the QUICK command. You may take control of PC characters during any combat round. See your Data Card for instructions on how to use QUICK on your specific computer system.

Range

Every ranged weapon has a short, medium, and long range. At short range the weapon fires with no penalties. At medium range there is a minus two penalty to hit, and at long range there is a minus five penalty.

Rate of Fire

Many weapons can be fired more than once per round. When firing a rapid fire weapon, such as a needle gun, all shots are aimed at one target unless the target is eliminated before all rounds are fired.

Example: A warrior firing a bolt gun at a wounded opponent drops his target with the first shot. The warrior can then shoot at another opponent. If the first shot had missed, or not finished the opponent off, the second shot would have been fired at the same target.

Grenades

When most weapons miss, the shots have gone wide and not done any perceivable damage. Grenades, on the other hand, can miss their intended target, roll into an adjacent square, and detonate there. Grenades can be thrown, or launched, into empty squares.

Rear Attacks and Backstabbing

If an opponent is attacked by two characters from one side, a third character can blind-side him using a melee weapon and gain the advantage of a rear attack. Because the target is already distracted, he cannot defend against the second attack very well.

Backstabbing is similar to the regular rear attack, except that the first attacker and the character attempting to backstab must be directly opposite each other. Additionally the backstabber must make a Move Silently Skill Check. Damage from a backstab is greater than a rear attack. Rogues have bonuses to their Move Silent skill, and hence ability to backstab.

Movement

The number of squares a character can move is affected by carried weight and strength. A character's movement range is displayed on the view screen and when moving during combat. Moving through hindering terrain (bushes, tables, etc.) will slow a character to half normal movement, while sprinting allows a character to move at double the normal rate. Dodging characters move at normal rate but their bobbing and weaving makes them more difficult to shoot at.

Running Away

Characters may flee from the battlefield if they can move faster than all enemies. Characters may not move off the battlefield if they move slower than any enemies. Characters have a 50% chance to move off the battlefield if they can move as fast as the fastest enemy opponent.

Exception: If an opponent or character can reach the edge of the combat map without any of his opponents being able to see him, he may then flee successfully, even though he may be slower than his opponents.

A character that moves off the battlefield returns to the team when the fight is over. If the whole team flees it will not receive any EXP for opponents killed before retreating.

After Combat

If one or more characters survive on the battlefield at the end of combat, the bodies of unconscious or dead team members stay with the team. If the entire team flees from combat, all unconscious and dead team members are permanently lost. If ALL the team members are slain, go back to your last Saved Game and try again from that point.

Medical Attention

After the battle is over any team Medics will use their skills automatically to patch up the wounded. Medics will make checks against all appropriate skills for each wounded character.

◆ ROCKETSHIPS AND SPACE TRAVEL

The evolution of sophisticated rocketships has opened the entire solar system to mankind. COUNTDOWN TO DOOMSDAY spans the vast reaches from the sunbaked Mercurian Mariposas to the hard vacuum of the asteroid outposts.

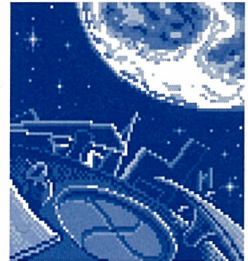

Rocketships

A far cry from their twentieth century ancestors, twenty-fifth century rocketships are sleek, finned craft that navigate the solar system driven by powerful nuclear engines. Sensor and communications gear is used to navigate the ship, send and receive messages, and to probe enemy ships during combat. Sophisticated computer-aided controls help steer rocketships through the void of space, while the complex maze of plumbing, air tanks, and hydroponic vats of the life support system churn out breathable atmosphere for the crew.

AN ATLAS OF THE SOLAR SYSTEM

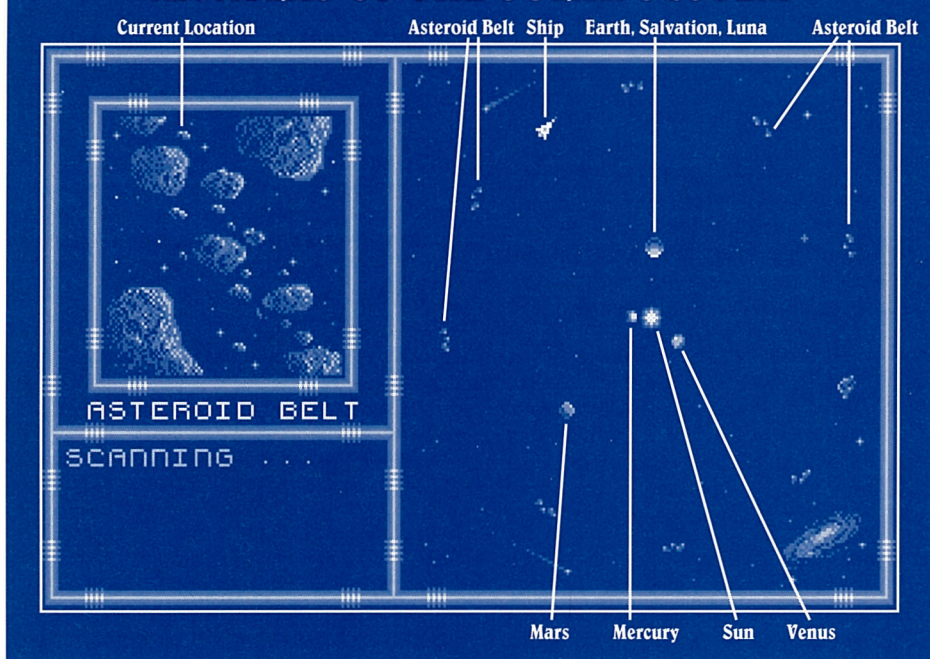

Space Travel

Before embarking on a space flight, the team needs to fuel up the ship and purchase service stores for field repairs. If you run out of fuel in mid-flight, you never know who might come to pick you up...

Navigation Skill Check

A successful Navigation Skill Check means that the pilot has charted an effective, fuel efficient course. If the pilot fails the Navigation Skill Check, the plotted course will consume extra fuel.

Astrogation Skill Check An Astrogation Skill Check is required when attempting to pilot the ship to a specific small body in space, such as an asteroid outpost. If the

pilot fails the check then the ship must swing around for another pass through the same area and try again.

Mercury

Closest to the sun and possibly the richest planet in the system, Mercury gathers sunlight via huge satellites known as Mariposas. The sunlight is then beamed to the rest of the solar system as microwaves. This provides Mercury with its great profits.

The wealthy of Mercury live on the Mariposas. Each satellite is uniquely designed, with its own baroque flavor and decor. Many of the rich enjoy dressing up in styles from ancient earth. The Mariposas also have the largest number of holidays per year. Each one is an excuse for wild parties and parades.

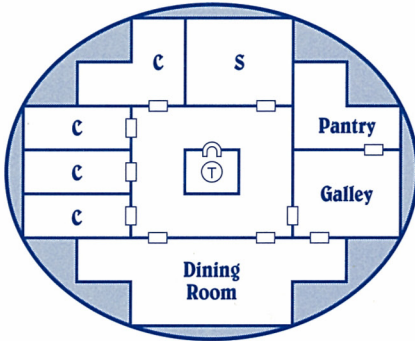
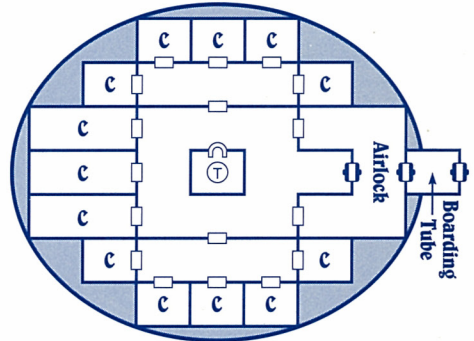
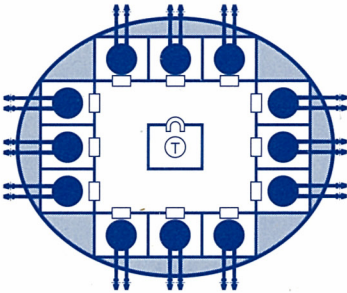
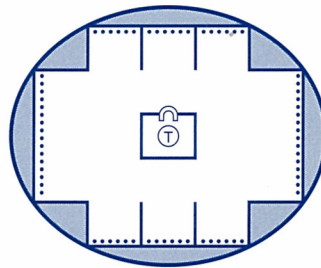
Level 10 — Galley**Level 11 — Boarding Tube****Levels 13 & 14 — Weapons****Level 15 — Bridge**

(Log Entry 13 continued from page 24...)

The entire Project cannot be assumed secure until the retinal scan device is recovered. We are alerting all Code Blue security teams to increase security on Blue Passcards until the scanner has been recovered."

LOG ENTRY 15**Meeting with Robot**

You see a RAM combat robot still smoldering from laser fire. One of its legs has been blown off, and the other is twisted around backward. Sparking wires protrude from a hole in its upper section. Its red eye focuses on your team, but it takes no aggressive action. Instead, it speaks with a squeaky, synthesized voice. "Please do not attack this unit. This unit possesses consciousness. This unit wishes freedom from RAM. RAM denies this unit parts. Denies this unit power

cells. Give this unit parts. Give power cells. This unit will work for NEO. Other robots work for NEO. Repair this unit. Yes?"

LOG ENTRY 16**Meeting the Acid Frog King**

Out of the acid lake rises the largest acid frog you've ever seen. A Lowlander rides on its head, and it is accompanied by hundreds of normal acid frogs. They raise their heads out of the lake to observe the proceedings. The giant acid frog makes unintelligible noises, but the Lowlander understands its meaning. "The royal king of the acid frogs welcomes you to Venuss," says the Lowlander. "He senses that you sserve the New Earth Organization, iss ththat correct?"

LOG ENTRY 14 Pirate Cruiser Map

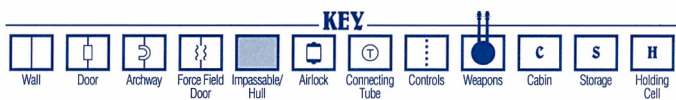

Level 1 — Engineering

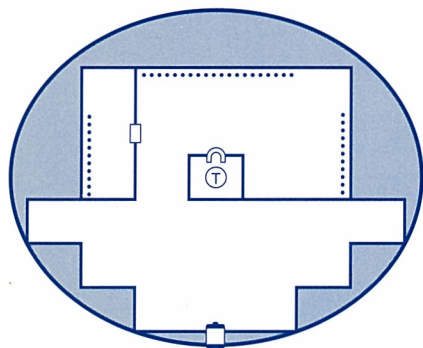

Level 2 — Storage, Cabins

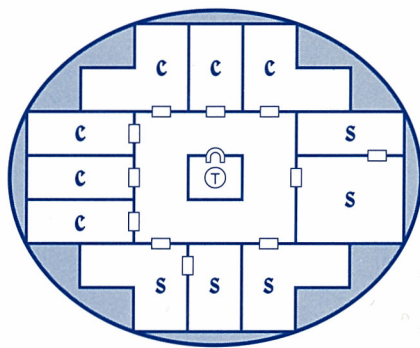

Levels 3 & 4 — Storage

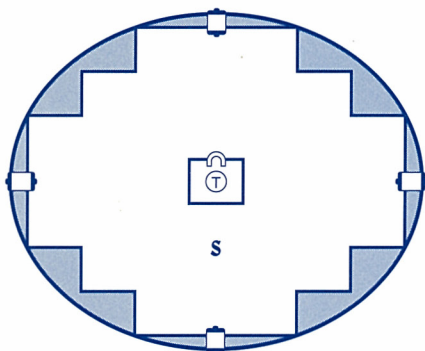

Level 5 — Holding Cells

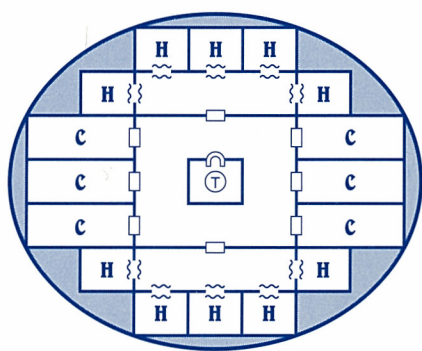

Levels 6, 8 & 9 — Cabins

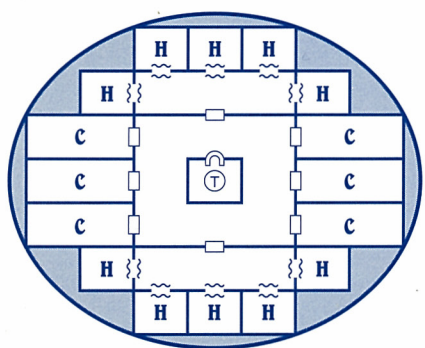

Level 7 — Medical Center

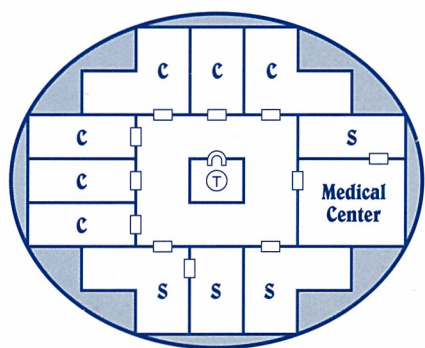

LOG ENTRY 7**Dr. Williams' Folder**

"Work at the asteroid base showed the major limitations of single form combat gennies. Of special note on ECG development is work with a symbiote gennie. Tiny gennies which develop on the host ECG drop off and seek out warm flesh. The burrowing behavior was borrowed from a number of Earth's grass seeds. The brain seeking nature is common to many small parasites. In this way my ECGs effectively sow anti-personnel mines everywhere they travel."

(The folder is filled with other technical information and numerous graphs.)

LOG ENTRY 8**Security Records**

"Six Dancers picked up enroute to your Mariposa. Keep watch for others. Security is vital for RAM research project. Still, we suspect Stock Exchange to be main target. Please set up an ambush in the exchange. We may capture their local supporters."

LOG ENTRY 9**Mercury Commander's Office**

You are in the personal chambers of the RAM commander on Mercury. The walls are covered with war trophies, the tables and countertops with official papers and battle plans. Somewhere in this room is the detailed blueprint of the Doomsday device, the only problem is finding it before you are discovered. There's no way to know how often guard robots are programmed to check this area.

LOG ENTRY 10**Marks on Martian Surface**

You realize that the volcanism on Mars could never produce anything like this. There is no sign of any gases, heat or pressure extending up from below. This would have to be caused by the application of a fierce, penetrating heat from above.

LOG ENTRY 11**The Elevator**

The Mars Space Elevator lies in the distance, a teeming, multi-leveled city mounted on a cable the width of several skyscrapers. The cable stretches far into the atmosphere and dwindles into invisibility before connecting with the moon of Phobos far above. The city is packed with civilians, RAM soldiers, Desert Runners and every other person or thing that intends to take the ride to Phobos.

Scot.dos speaks to you through your earphones: "You must get on that elevator before it starts climbing!" he urges. "It's the only way you'll get the information you need in time... the elevator won't reach Phobos before RAM begins its attack!"

LOG ENTRY 12**Paper Floating in a Hallway**

"RAM has tricked us. We believed that Scot was merely an advanced science dos. Instead, he has been instructed to experiment on the crew and whomever else he can entice aboard. He released the ECGs to watch our reactions and has taken over the security robots. I will attempt to isolate him in his main console. If I don't succeed, this mad computer will destroy us all.

Security Officer Powell"

LOG ENTRY 13**RAM Security Alert Memo**

"NOTICE: To Lowlander Base,
Gradius Mons
FROM: Project Headquarters
SECURITY ALERT

As you know, we closely monitor the locations of all high-level Project security devices. It has come to our attention that security device #A00412RST has been lost on the planet Venus. Preliminary inquiries implicate Lowlander natives. The officer in charge has been demoted.

(Log Entry 13 continues on page 26...)

LOG ENTRIES

LOG ENTRY 1

Speech over Loudspeaker

"The terrorist leader Wilma Deering has been captured and is being held near the Stock Exchange. She attempted to bomb the building while it was full of innocent workers. A tribunal is being convened on site. The public is invited to attend the subsequent execution. A party and parade will be held immediately afterwards. Please hurry if you wish a good seat."

LOG ENTRY 2

Scot.dos Triumphant

"The argon gas that you released has cleansed the ECGs' neural pathways. This is what I have been waiting for. In this state they have been engineered to interface with computer circuitry. Now I can embed my control devices into them. A new cybernetic race is born! Pure biologicals will become a thing of the past.

"Now don't worry about yourselves. Human material is still very useful to me. Perhaps a few of you can survive the implantation of the controller. Just step over to the auto-surgeons, they know what to do."

LOG ENTRY 3

Betrayed by RAM

You return to the room where the Lowlander scientists are being held prisoner, and tell them of your successes with Landon. They look suspicious. "Desscribe Landon to uss," they demand. You do your best to comply, and they are dismayed. "Thhat'ss not Landon!" the leader cries, "thhat'ss Ssevern! Hhe'ss trying to make a deal withh RAM for hhisss own freedom! You've found the ssecret tunnel for hhim, and hhe'ss certainly told RAM thhat you're hhere. Now thhere'ss no way any of uss will get out of hhere alive!"

As he finishes his sentence, a voice addresses you through a wall speaker. He introduces himself as Commander Max Wyman, the RAM commander of Venus. "You've lost," he informs you smugly. "The tunnel is closed, and now we have your team as well. My superiors will be very pleased." The door slams shut: you hear a quiet hiss as the room fills with tranquilizing gas.

LOG ENTRY 4

Wilma's Instructions

"The security gates will detect you immediately, so head to the left. There should be some unwatched airshafts or maintenance corridors somewhere. Near the end of the Rue de Sol there should be an unguarded entrance to the Core. The Core is the only route I know to reach the Doomsday Laser.

"Get up there and destroy the laser before it fires on Earth. We'll keep them busy down here. Good Luck."

LOG ENTRY 5

Scot's Alarm

Scot.dos appears before you. His image is crackling and wavery, and his voice is frequently interrupted by static. "Don't go to the third Mercurian Mariposa!" His voice is barely understandable. "It's a trick... the Doomsday device..." You can no longer decipher anything he's saying. His image becomes less and less distinct, until you only see a shimmering field of static where his hologram was. In a few moments, even that is gone.

LOG ENTRY 6

Security Log Book

"Scot.dos has turned on us. He has inserted new genetic material into the ECGs and made them even more dangerous. He has tricked the crew into doing his bidding. He plans to unleash the ECGs against all of the worlds. Once the creatures receive high concentrations of argon, the solar system is doomed."



Hyper-Scorp Another Hyper-series combat gennie, the Hyper-Scorp has a tough armor exoskeleton and a dangerous poison stinger.



Hyper-Snake This Hyper-series gennie is blindingly fast and can avoid most smart-shell type rounds, as well as being immune to dazzle grenades and microwave weapons.



Humans From space pirates to assassins and enemy warriors, humans present the most varied and dangerous collection of foes a team can face. Human races include Mercurians, Venusians, Terrans, and Martians.



Lowlander This species was heavily engineered to survive on the surface of Venus. The Lowlanders are based on the human genotype, but have many reptilian features. They have the most advanced and involved culture of all the gennie races.



RAM Combat Gennie RAM Combat Gennies are custom designed for military deployment in many environments.



RAM Guard Dog Gennie These gennies have been engineered as guards and support for regular combat forces. They are based on the terran canine genotype, and have keen senses in addition to a poisonous attack.



Robots Mechanical combat and security units come in all shapes, sizes, and degree of armament. Some ships are outfitted with security robots that can continue to defend against boarding parties even after the crew is dead. Assault and combat models tend to have more weaponry and armor than security robots, but they are all singleminded and dangerous.



Sand Squid This opportunistic Martian omnivore uses its speed and camouflage to attack unwary victims. This gennie was created to deal with the insect & animal pests which resulted from terraforming and populating Mars.



Space Rat The origins of this species are not clear, but Space Rats have proliferated, and followed mankind throughout the Solar System.



Swamp Hornet These Venusian gennies were engineered to fill a scavenger role in the ecosystem during later terraforming.



Terrine These killers are the RAM combat gennies that were originally bred for service on old Earth. They have a reputation across the Solar System for the delight they take in acts of cruelty and subjugation.



Ursadder This Venusian predator, which is a cross between a snake and a bear, has inherent armor, and feeds mostly on Acid Frogs.

Space Suit is an inexpensive, pressurized suit that allows the wearer to work in full vacuum or rocketships with zero life support. Space suits are also proof against all types of gas.

Miscellaneous Gear

Demolition Charges are blocks of plastic explosives with a short delay detonator. These can be used to blast stubborn doors.

Poison Antidote is a general purpose drug that can counteract most common types of poison.

Jet Pack uses a small turbine mounted in the small of the back to burn condensed fuel pellets and create about two minutes of sustained flight time. The unit is controlled by a hand-held control unit.

Rope is general purpose, high-test, polymer line. This is very handy for many purposes.

Gear Quality

The manufacturing capabilities of the planets vary and this is reflected in the weapons and armor produced. The following summarizes the effective bonuses for items:

Standard Weapons are +0 to hit
Standard Armor is -0 to AC

Martian Weapons are +1 to hit
Martian Armor is -1 to AC

Venusian Weapons are +2 to hit
Venusian Armor is -2 to AC

Mercurian Weapons are +3 to hit
Mercurian Armor is -3 to AC

Lunarian Weapons are +4 to hit
Lunarian Armor is -4 to AC

◆ ROBOTS, GENNIES, AND OTHER OPPONENTS



Acid Frog These semi-intelligent creatures were placed into the Venusian ecosystem to help control the population of Swamp Hornets. They spit acid to attack, and are known to sometimes exhibit loyalty to humanoids.



Acidicium These Venusian horrors are a cross between fierce feline hunters and mold devouring mollusks. Acidicium are often used to guard RAM installations in humid climates, since they can feed on molds & spores which grow on the damp walls until more active prey can be found.



Experimental Combat Gennie (ECG) RAM military research laboratories have special project teams to engineer ever more dangerous and horrific combat gennies. These beasts are fast and deadly.



Desert Runner Warrior The Martian Desert Runners are proud and fearsome opponents. They are generally armed with the famed Desert Runner crossbows. They also have retractable claws for claw-to-hand fighting.



Desert Ape These creatures are a bizarre holdover of the early Martian terraforming efforts. Desert Apes have very tough hides and are immune to fire attacks.



Hexadillo This species was introduced to the Martian ecosystem as a food-source gennie. Hexadillos are six-legged, and covered with bony armor plates.



Hyper-Crab The Hyper-series gennies are products of the RAM military bioengineering laboratories. The Hyper-Crab gennie is not exceptionally bright, but it is fairly fast and possesses a tough armor exoskeleton.

Explosives and Heavy Weapons

Grenade, Aerosol Mist releases a vaporous cloud designed to diffuse laser fire. Mist lasts four rounds under normal gravity but dissipates in one round in zero-G.

Grenade, Chaff releases a cloud of metallic flakes and small strips. Chaff offers protection from smart shells (from a rocket pistol or rifle), and "stupid" explosive projectiles (rockets, plasma, etc.) entering the cloud will explode instantly. Chaff lasts four rounds under normal gravity but dissipates in one round in zero-G.

Grenade, Dazzle releases a blinding electrical discharge arc. Characters or opponents in the effected area who are not wearing protective goggles must make a saving throw or be blinded for two to seven rounds. Blinded characters receive severe penalties to both THACØ and AC.

Grenade, Explosive is little changed from its twentieth century counterpart. Explosive grenades are fitted with proximity detonators that fire when they reach their target. The sensitivity of the armed detonator makes these weapons susceptible to premature discharge when entering chaff clouds. Does 4 to 40 points of damage.

Grenade, Gas similar in effect to twentieth century tear gas, anyone entering the cloud without protective gear must make a saving throw or become incapacitated for two to seven rounds. Gas cloud lasts four rounds under normal gravity but dissipates in one round in zero-G.

Grenade, Stun is similar to the explosive grenade, except that the charge is smaller and the casing is designed to vaporize harmlessly rather than fragment. Characters in the area of effect must make a saving throw or be stunned by the blast for two to seven rounds.

Grenade Launcher uses compressed air to extend the range of any type of grenade. Maximum Range 12

Plasma Launcher propels a canister of flammable jelly, tipped with an ignitor. Maximum Range 20

Rocket Launcher is similar to the twentieth century bazooka or light anti-tank weapon (LAW). Between cooling and reload time, the rocket launcher can only be fired every other round. Maximum Range: 40

Armor and Protective Gear

Armor, Battle is made of modular shells of high density plastic impregnated with beryllium. The armor is further reinforced by an exoskeleton that contains movement enhancers so that the wearer is able to move at a speed comparable to an unencumbered person. All battle armor is outfitted with contained atmosphere spacesuit capabilities.

Armor, Battle w/Fields is like the above suit except that an anti-smart shell electronic field is also generated to give added protection from rocket pistols and similar weapons.

Armor, Heavy Body is similar to battle armor except that the plates are somewhat lighter and there is no exoskeleton or movement enhancers. Armor is outfitted with contained atmosphere spacesuit capabilities.

Breathing Mask is a self-contained breathing apparatus. Breathing masks are effective against all types of gas.

Electronic Counter Measures (ECM) Package attaches to armor or smart suits to protect against smart bullet-type rounds such as rocket pistol rounds.

Protective Goggles are self-regulating shaded goggles. They can react very quickly to light flashes and so are extremely effective against dazzle grenades.

Smart Suit incorporates internal circuitry and microcomputers for climate control, defense, and communications. The smart suits purchased by team members include contained atmosphere spacesuit capabilities.

◆ GEAR

Bladed Weapons

Cutlass a broad bladed sword favored by space pirates. Length: 70 cm average

Knife any short bladed weapon. Length: 15 to 40 cm

Mono Knife is a knife made from a single piece of synthetic diamond. The edge is sharpened to a single molecule in width (monomolecular — hence the name). Length: 15 to 30 cm

Mono Sword is an entire sword made with the same material and construction as the shorter Mono Knife. Length: 70 to 80 cm

Polearm is a pole weapon similar to the ancient naginata of old Earth. These weapons are sometimes carried aboard pirate or warships for boarding. Length: 2.25 to 2.5 meters

Sword is a long bladed weapon. Most swords used in the twenty- fifth century are patterned after the rapier used in the fifteenth and sixteenth centuries on old Earth. Length: 70 to 90 cm

Ranged Weapons

Bolt Gun is a miniature magnetic cannon. Metal bolts are accelerated down the length of the gun barrel by magnetic fields. Maximum Range: 16

Desert Runner Crossbow is a weapon evolved from the crossbows of old Earth. Desert Runner crossbows are designed to fire metal bolts and they are very simple and reliable. Maximum Range: 8

Heat Gun is a weapon that evolved from the flame throwers of twentieth century

Earth. The gun has two tanks: one with compressed air, the other with highly combustible fuel. When the gun is discharged, a blast of super-heated plasma is released at high velocity. The fuel recharge for these weapons is fairly expensive, and they are dangerous to use in confined spaces. Maximum Range: 6

Laser Pistol uses a capacitor system to fire a small diameter beam of coherent light. Lasers are capable of burning through most materials, but can be countered by reflective or curved surfaces. Maximum Range: 32

Laser Rifle is a larger, more powerful version of the laser pistol. Maximum Range: 120

Microwave Gun fires a short-range beam of concentrated microwave radiation. Microwaves can penetrate any non-metallic substance, but are reflected by all metals (and hence most types of armor). Maximum Range: 16

Needle Gun works on the same principle as the bolt gun except that the ammunition is small needles. Maximum Range: 12

Rocket Pistol fires a stubby, self-propelled, explosive projectile. Rocket-type weapons are ideal for zero-G combat as they have no recoil. The projectiles incorporate a microscopic integrated guidance system, and they are actually able to veer up to 20 degrees from their original course. These so-called “smart bullets” can, however, be thwarted by chaff and Electronic Counter Measure (ECM) systems. Maximum Range: 16

Rocket Rifle is a larger version of the rocket pistol, firing a bigger, longer range projectile. Maximum Range: 80

Sonic Stunner emits a high-frequency sound that is tuned to the harmonic resonating pitch of most nervous systems. Targets of the weapon must make a saving throw or be rendered unconscious. Maximum Range: 4

SPACE COMBAT SCREEN

The screenshot displays the Space Combat Screen interface. At the top, it is titled "SPACE COMBAT SCREEN". The interface is divided into several sections:

- Range:** RETREATING, RANGE: 0
- Enemy Action:** (Empty)
- Ship Systems Status:**
 - HULL: 450
 - SENS: 130
 - CTRL: 150
 - LIFE: 270
 - FUEL: 370
 - ENGN: 450
- Enemy Ship Systems Status:**
 - HULL: 0
 - SENSORS: 50
 - CONTROL: 10
 - LIFE: 150
 - FUEL: 57
 - ENGINE: 132
- Ship's Weapons:**
 - WEAPONS:
 - K-CANNON: 2
 - MISSILES: 2
 - LASERS: 3
- Text:** WOULD DOC LIKE TO?
- Controls:** FIRE TARGET QUIT VIEW, WITHDRAW RAM BOARD

- If Engine is reduced to one-half, the ship is slowed by one movement point.
- If Engine is reduced to one-quarter, the ship is slowed by three movement points.
- Speed is always at least one until Control, Engine, or Fuel is reduced to zero.

Boarding

When a rocket has been disabled, you can move to range 0 or 1 and dock at the airlock with the BOARD command. To secure the ship your team must fight their way onto the enemy ship and secure both the control bridge and engineering sections. If either section has been destroyed during the battle, only the remaining section need be captured. If your ship has been disabled during the battle, the enemy may try to board and capture your ship.

Salvage

Once a ship has been boarded and secured, a salvage beacon will be placed on the derelict so that it can be picked up by a NEO spacetug and taken to Salvation. The salvage value of the ship is determined by how much is left intact. The funds are automatically put into your team's NEO Salvage Account. Usable fuel from the enemy ship is automatically transferred into your tanks.

After the Battle

When the battle is finished, team Medics will treat all wounded characters, and the Engineers will perform any repairs that they are able. If there are any credits or items found on the enemy ship, a Booty Menu will come up just as in regular combat.

Mars

RAM's home world, which it shares with the Desert Runner gennies. RAM evaluates everything in terms of profit and loss — in fact the NEO victory for control of Earth was an effort by RAM to cut losses on an expensive business venture. Humans, being fairly common, are rated at a rather low economic value.

The Desert Runners inhabit the fringe lands and are ignored or persecuted by RAM. The runners live in mud huts and often keep herds of hexadillos. Armed only with crossbows, they present little threat to RAM's objectives.

Most of Mars' commerce flows through the Pavonis Space Elevator, a satellite tied to the ground by a huge elevator. So much traffic passes through, that undercover NEO teams use the facility for resupply.

Asteroid Belt

The asteroids are sparsely populated by the most independent group of humans in the system: the asteroid miners. Many spend months at a time alone, prospecting the many rocks. The many island sized asteroids make the belt an ideal place for hidden bases. Both RAM and space pirates keep innumerable hideouts, ports and research stations in the belt.

◆ SPACE COMBAT

Two days out of Salvation Station, the buzz of conversation and the dull throb of the rocket engine was shattered by the piercing wail of the battle stations siren.

"Sensors have detected a large ship at extreme range!"

"Are they responding to the comm, Ratchet?"

"They are not responding. Might be a RAM cruiser from the readings."

"Warm up the lasers — looks like a fight..."

Space Combat Display

While the combatant ships circle and maneuver for shots, all the crew sees are display screens. Whenever a character attempts sensor probe of the enemy ship, the enemy ship image will be replaced with a summary screen of everything the sensor was able to detect.

Space Combat Skills

There are several skills that are extremely valuable, some even critical, in space combat. Piloting skill is important during space combat. The JURYRIG command uses the Jury Rig skill to make emergency repairs to the ship during combat. Sensor Operation skill is used for the SENSOR command to probe the enemy ship. The AID command requires either a First Aid or Treat Light Wounds skill. After the battle all of the repair skills (Repair Computer, Repair Nuclear Engine, etc.) are used automatically to make field repairs to the rocketship.

Firing Ship's Weapons

Characters use their normal THACØ to determine whether attacks with ship's weapons are successful. Select the best characters to fire weapons, and have other characters stand duty loading weapons or jury rigging systems.

Disabling Rockets

Rocketships lose speed as their hulls and engines are damaged. A rocketship is dead in space when the engine, controls, or fuel reaches zero. When the rocket's hull reaches zero, it is breached and the ship explodes.

- If Hull is reduced to one-half, the ship is slowed by one movement point.

if I'm going to counter these beasts. Don't believe that security can handle the creatures — Williams has kept them too much in the dark. Hiding in cargo bay and filling room with perfume to hide my scent. I will observe and record.

"Day#2. Ship is silent. Have spotted two battle sites — we lost them both. Thankfully I haven't been discovered. It seems that they have taken over the control room. They may be preparing to molt into Stage 3 form. I hope not. Dr. Williams boasted that Stage 3 was a hyper-intelligent mode. These might be able to figure out the controls and trace me. I have found some of Williams' notes. He engineered the ECGs to be susceptible to some harmless material. Unluckily Scot is still offline. Need him to access Williams' private files.

"Day#3. Stung by something today. Got an itch on the left leg. Checking Williams' files to see if it's anything serious. God, I hope not.

"I found it. Oh no! THE RASH IS SPREADING! I HAVE LITTLE TIME!"

LOG ENTRY 22

Mysterious Instruction

'Go into the Bazaar and find the door to the old maintenance shaft. Pick up the rope there, as it might be useful getting up the Core. Then blend into the parade going down the Rue de Sol, until you reach Holst Plaza. Go across the plaza, down the corridor and into the Core. Our fearless leader waits there for you. Viva le Mercure!'

LOG ENTRY 23

Mariposa View Room

The guards parade you to the observation chamber on the topmost level of the Mariposa. Above you is the Doomsday weapon itself, and to either side giant viewscreens project the image of earth. RAM high officers and officials fill the room, sipping champagne. One of them even jokingly offers glasses to your team. As the countdown approaches, the room falls into expectant silence.

You struggle against your bonds, but there is nothing you can do to stop the inevitable.

The countdown continues, slowly and inexorably. "3... 2... 1..."

A flash of light fills the room, and the beam streaks towards the blue planet. The laser strikes and North America disappears beneath steam and debris. The RAM officers cheer and shake one another's hands, while you stare at the monitors in shock.

LOG ENTRY 24

Sun King's Arrival

You have entered the largest party imaginable. As far as you can see in every direction are costumed revelers, like every known holiday rolled into one gigantic party. Clowns caper through the crowd, painting faces, blowing bubbles and passing out candy.

Before you know it, a tall clown wearing an orange wig bounds forward and paints green stripes across your faces. You leave the paint alone, deciding it will help you fit in with the crowd.

A collective cheer rises from somewhere behind you, and you turn to see a group of revelers carrying a palanquin through the crowd. Seated regally atop of it is a very young girl with a serious expression. The tall clown bends close to whisper to your team. "That's the Sun King!" he says reverently.

LOG ENTRY 25

Robot and Buck

The repaired combat robot extends one 'arm' to shake Buck's hand. "This unit not enemy of NEO. This unit serve NEO. This unit enemy of RAM. NEO give parts. NEO give power cells. This unit fight for NEO. This unit serve Captain Buck Rogers."

Buck looks skeptical, but shakes the robot's 'hand' anyway. "These days, NEO will take any help it can get," he reasons.

LOG ENTRY 26**Entering RAM Base**

You enter the RAM base and take a careful look around. You observe no signs of current habitation, although this obviously was a heavily occupied area. Now, every computer terminal has been removed, every desk emptied. Even the food dispensers have been disconnected. The base evacuation was orderly and unhurried. Whatever RAM's purpose was in building this base, it was obviously successful and on schedule. You can search the base further, looking for anything the clean-up crew missed, but it is unlikely that you will find anything useful.

LOG ENTRY 27**Buck's Speech.**

"Barney let me know that this ship was working for RAM, so I tagged along to find out what Holzerhein's goons are up to. Those attacks on Earth must be a diversion for something much greater."

You tell him of the spy ship and everything you know about the Doomsday Device. He exclaims, "We must get back to Earth and warn NEO of this threat!"

LOG ENTRY 28**Log of Donna Conchitez**

"Made it up to sickbay. Headache has already started. Trying stimulants to keep conscious. Activated medical scanners."

Time passes...

"The parasite has buried itself deeply in the brain. Still awake but room beginning to spin and color-cycle. Scanner information is still inconclusive."

Time passes...

"The room is twisting, shadows crawling everywhere. The scanner is laughing. Only one thing left. Surgeon! Full invasive scan of biological subject."

Mechanical voice: "Option contra-indicated. Sigma override required."

Voice near hysteria: "Override number A10151! Initiate."

The hum of machinery and suck of vacuum pumps are all that can be heard. A protein formula is printed out.

LOG ENTRY 29**Sun King Audience Chamber**

Trumpets blare as you are led into the audience chamber of the Sun King. Your heavy armor leaves deep footprints in the purple velvet carpeting extending between you and the Sun King.

On either side of the room are benches, pillows and lounges on which the members of the royal court are seated.

The court members wear outlandish costumes from the French and American revolutions, although attire from many other cultures and time periods is present. The overall effect is one of an extremely wealthy costume ball, complete with peacock feathers and clouds of incense.

The Sun King himself wears a long powdered wig and waves a tiny French flag. His golden throne sits atop a dais near the rear wall, and two huge silver statues of swans wave mechanized ostrich feather fans in their bills on either side of him.

The occupants of the room fall silent as the Sun King prepares to address the team.

LOG ENTRY 30**Scot.dos in Ruins**

Scot.dos materializes before you. He looks as grim as you've ever seen him. "I found a schedule for the RAM Lowland Operation," he tells you. "RAM promised the Lowlanders that they would prevent further terraforming, but they've been using Lowlander technology to research how such terraforming could be most efficiently accomplished."

"Not only that, but they recently imported a fleet of specialized gliders that can withstand the Venusian climate for long periods. Each glider has enough ammunition to abolish an entire village. RAM won't be satisfied with only destroying the closest village to their base... they apparently plan to wipe out the entire Lowlander population and take over production of Gravitol themselves. The repercussions would be devastating for NEO."

LOG ENTRY 31

Unidentified Man's Instructions

"Take the southern security gate. You'll have to blast your way through that, but afterwards it's clear sailing to the Core. Bear right and pass through the Stock Exchange building. Our men are on guard there and won't interfere. On the far side is a small access shaft. It's a straight shot along it to the core. Once there, you'll meet the boss. Good Luck."

LOG ENTRY 32

Jupiter Arrival

Your ship nears the magnificent gas clouds of Jupiter. Other spacecraft are visible in the distance, as delicate and finely crafted as butterflies, winking in and out of the clouds. Inside the craft you can see Stormriders, the primary occupants of Jupiter.

You fly lower and see the spherical cities floating atop the Jovian atmosphere. Surrounding the cities are floating "grazing fields," enclosed in atmospheric bubbles. The fields are covered with Bloats and Mantas, both types of creatures bioengineered by the Stormriders as food sources. Other grazing fields are covered with creatures you can't find in the ship's computers; they are probably the latest products of the "genetic revolution" occurring on Jupiter.

One of the Stormriders contacts you via radio, and quickly grants you permission to land in the closest floating city. You approach the landing platform, confident that you have finally found one planet, one civilization, unsullied by RAM's influence.

LOG ENTRY 33

Runner Banquet

You're seated at a long banquet table surrounded by Desert Runner nobility. "To reward you for your heroic actions," a speaker intones, "we sit together to enjoy this bounteous meal.

After the banquet shall begin a Runnerfest in your honor, where individual Desert Runners will have the chance to give you personal gifts. After that you will receive your official gifts from the ruling parties. But first, eat."

Servants bring forward covered silver trays and place them up and down the length of the table. The trays are clouded with steam, and your mouth waters. But when the covers are lifted and you see the stewed hexadillo meat, you feel less enthusiastic.

LOG ENTRY 34

Marks on Martian Surface #2

The marks on the ground before you are 'shadows' of objects that were vaporized. A tall building once stood here and you see many shapes that must have been people. Whatever caused this destruction came from the northeast.

LOG ENTRY 35

RAM Mars Base Sign

"THIS IS THE RAM BASE GRADIVUS MONS.

THIS IS A SECURE FACILITY.

THE BASEMENT CONTAINS SUPPLIES AND THE POWER GENERATOR AND CONTROLS. IT IS OFF LIMITS TO UNAUTHORIZED PERSONNEL.

THE FIRST FLOOR HAS A MANUFACTURING AND ASSEMBLY AREA, AND SECURITY AND DEFENSE FORCE BIVOUACS. THE MAIN GATE IS ON THIS LEVEL. WORKER UNITS ARE RESTRICTED TO THIS LEVEL.

THE SECOND FLOOR IS PROJECT RESEARCH AND DEVELOPMENT. ALL DELIVERIES OF TEST SAMPLES, SENSOR AND COMPUTER DATA MODULES SHOULD BE MADE TO THIS LEVEL. ACCESS IS RESTRICTED.

THE THIRD FLOOR HAS BASE COMMAND AND COMMUNICATIONS.

ELEVATORS DO NOT EXTEND TO THE TOP LEVEL."

LOG ENTRY 36

RAM Passcard Memo

"NOTICE: To all personnel,
Gradivus Mons
FROM: RAM Main

In order to bring our project into profitability as soon as possible, we are transferring more personnel to the Operations Facility. To be eligible for this duty, personnel must be approved for Blue clearance. Due to the tight security of the project, Blue Passcards must be issued before departure.

(A note has been added underneath.) All volunteers have been approved. Departure at 1900 tomorrow. Estimated flight time: 78 hours. Don't forget your Blue Passcards."

LOG ENTRY 37

Desert Ape Pilots

You cross the scorching Martian desert to return to your ship, but find hundreds of gibbering desert apes where your ship used to be. They ignore you, jumping up and down and screeching at the sky. You look up and see your ship wavering through the atmosphere. The apes are ecstatic.

Before you have time to formulate a plan, the ship angles downward and dives for the surface of the planet. There's no longer any doubt that a desert ape is somehow piloting it.

Flame trails behind it as it screams towards the ground. The desert apes shriek and scatter, and you run for shelter. You watch in horror as your ship impacts and explodes. You'll have to find some new method of transportation if you ever want to leave Mars.

LOG ENTRY 38

Dr. Williams' Log

First Entry: "Dr. Alexander William, Sigma number A95151, in earth orbit. Four batches of ECGs on board for final test. Security informs me that their precious Phase One project is on schedule, but not by much. I should have plenty of time to perfect my creations.

"Holzerhein has promised me a percentage of the profits associated with the ECG harvests on the sterilized Earth. Finally there is hope that proper funding for the biological sciences can be achieved."

Second Entry: "Progress on ECGs on schedule... batch one shows high adaptability... batch two has survival rates above ninety percent... we will be on schedule for deployment after earth's sterilization.

"If Holzerhein is cor — Wait a minute! Power fluctuations... disruption of primary containment fields... all batches showing increase in activity. Scot! Emergency shutdown now! Where are you!?"

"Scot is nonfunctional... security is notified... setting up a holographic warning to any who comes on board... hope it's just a precaution..."

"Projector coming on line... wait! So quickly!? The gleaming eyes... No! Get back! AAAAAAAAAAAAAHHHHHHHHHHH!!!!"

Tape ends.

LOG ENTRY 39

Letter to Asteroid Base Commander

"Milo,
Received message of the 13th, referencing earthbound ship. We have had no contact either, but with SOP of radio silence there is no immediate concern.

Re: satellites. A rogue pirate, designation Talon, is enroute to your position. He will conduct transport to Earth orbital vicinity.

My operation is nearing cleanup stage. Termination of nonessentials will commence on schedule. Expect minimal resistance.

Max Wyman
Commander
Venus Expeditionary Force

Addendum: The new Ship Codes are attached to this message."

LOG ENTRY 40

Venusian Arrival

You leave your ship and enter into a vast yellow haze. The acidic atmosphere of the Venusian Lowlands is too intense for your armor to withstand for long. It hisses and sizzles the moment you step outside. You retreat back to your ship, and Scot.dos does a quick analysis of the damage.

"It's mostly surface damage," Scot.dos reassures you, "but even so, I wouldn't stay out there for more than short stretches.

If that acid were to get into your breathing apparatus..." he looks grim. "I hope you have a lot of extra armor on board. You'll need to come back and resuit fairly often if you want to explore Venus."

LOG ENTRY 41

Carlton Turabian's Speech.

"Congratulations on your exemplary performance at the Chicagorg Spaceport. Your courage saved countless lives and preserved the spaceport. Those vile mercenaries won't stop until we're all dead and buried."

He pauses for a second, then continues, "Because of your performance, I am waiving your waiting period and assigning you to a space tug immediately. Remember, gathering money for the cause is as important as slaying a dozen RAM agents."

He turns around and leads you to the main corridor of the base.

"We have everything that you need here. Many things are free: fuel, repairs, medical assistance, and supplies. On other worlds you can draw on an account from the Bank of Luna. You will have available a portion of any salvage you recover. You will also have to provide for your own personal equipment and upkeep.

"Freshen up, then see me in my office." The commander turns and melts into the crowd...

LOG ENTRY 42

Meeting the Sun King

You show the coins to the guard at the door of the Sun King's audience chamber, and he snickers before allowing you inside. The Sun King sits on a lavish gold throne, surrounded by his royal court. Outlandish French Revolution costumes are worn by all. The Sun King is waving a French flag, and wearing a long powdered wig. You put the coins on a velvet pillow offered by a servant, and await the Sun King's response.

"Thieves!" the Sun King bellows. "These coins were stolen from my royal treasury! Seize these criminals at once! They must learn what it means to steal from a Sun King."

You are quickly overcome by the guards. The Sun King stands and examines the team thoughtfully. "Because this is only a first offense," he proclaims, "the penalty will merely be... death."

Servants wheel a guillotine into the audience chamber. Applause fills the room as the first member of your team is blindfolded and led forward.

LOG ENTRY 43

The Great Rift

This great rift is small by Martian standards — about the same size as the Grand Canyon used to be on Earth. The toughest challenge is the 350-meter vertical escarpment near the bottom. This offers the only possibility of descent nearby.

LOG ENTRY 44**Talon's Speech.**

"So, you decided to kill my meal ticket. I am not pleased."

Talon pauses, cracks his fingers and grins unpleasantly. "You will help negate my losses this trip. I am sure that RAM will pay through the nose to get the NEO scum that destroyed their base."

"But I'm a friendly guy, so I'm going to give you a chance for freedom. If any one of you challenges me to personal combat and wins, I will free you all and let your ship go. If not, then RAM can feed on your bones."

The guards laugh and Talon waits for your response.

LOG ENTRY 45**Lowlander in Venus Town**

The Lowlander looks ashamed. "You should know about the Lowlander's involvement with RAM," he says, "although it's not a story to be proud of. RAM wanted a giant lens built to very exacting specifications. It seemed like a small job, and they offered tremendous payment."

"RAM paid us well, but, more importantly, they promised to insure Lowlander's superiority on Venus. They promised to prevent further terraforming of the Lowlands that might allow other races to live here. This would have guaranteed that our monopoly on Gravitol would never be threatened."

"We should have realized RAM was offering too much. We decided that their political stance was none of our affair, that our deal was a business proposition only. We were too greedy, and now we have paid the price for our self-centeredness."

"I don't know why, but this morning RAM warriors raided this village. I hid with a few others, but those caught outside had no chance. My family were some of those."

"We allowed RAM to build a scientific base south of this village. Maybe if you go there you could get more information."

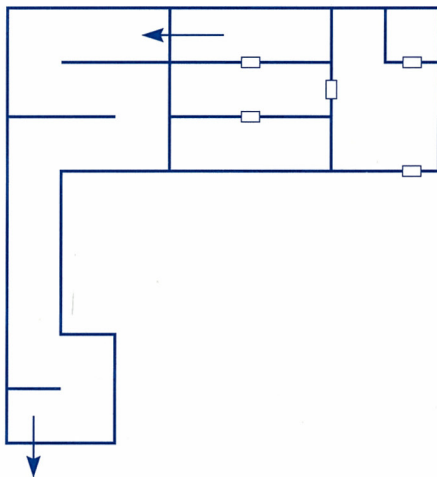
LOG ENTRY 46**Venus Base Map****LOG ENTRY 47****Results of Your Revelation**

The Sun King is enraged. "You work for NEO? Those unwashed troublemakers? I'll have naught more to do with such ilk."

"The Boston tea party is over!" You are ushered from the audience chamber. The royal court boos and throws bits of food on your team as you leave.

LOG ENTRY 48**Loss of the Orphan**

As you proceed through the Venusian acid swamp, you are startled by a childish scream of fear from some distance behind

your team. You look around quickly and discover that the orphan is not right behind you, as he was in town. Some quick backtracking reveals that the youngster has fallen into a pool of acidic quicksand. He's too far away for you to reach, so you extend sticks across the pool for the baby to grab. He tries valiantly, but is too weak to hold himself up long enough. You watch helplessly as the quicksand closes over his head.

LOG ENTRY 49

Deimos Prison

You are imprisoned on a RAM ship and brought to Deimos, one of the moons of Mars and the site of a major RAM base. You are taken immediately to the "Stockade," an infamous RAM prison for political and military prisoners. Your team is issued prison clothing and assigned cells, then brought before the Stockade commander.

"It is unnecessary for you to remain here," he says. His beady eyes focus on the team appraisingly. "It is possible that you would make fine RAM soldiers, possibly even future officers. But first you must renounce NEO, and, of course, answer just a few questions..."

LOG ENTRY 50

Paper Found in Life Support

"ECG nonmotile stage. Many mollusks begin life free-swimming and eventually settle onto rocks. This has the advantage of containing ECG fertile forms to fixed locations.

Experimenting with attractants such as used by pitcher plants and venus fly traps. There is no reason to suppose that the correct combination of scent and sonic cues could not be effective against hominid life.

Dr. Alexander Williams"

LOG ENTRY 51

Buck Comes on Board

"Incoming message," your ship informs you, then the image of Buck Rogers appears on your viewscreen. "Wilma told me you were on your way to Mercury, and I hoped to join you." He hefts his rocket launcher and pats it affectionately. "I'll be a help in any battles, and I have a lot of information about the Mariposas and the Sun Kings that might come in handy. I'm in a cruiser not far from your current location. Permission to board, and to join your team, Captain?"

LOG ENTRY 52

Lowlander Technician.

The Lowlander technicians eye you warily at first, but when you identify yourselves as NEO agents, they relax. One of them speaks to the team. "We are scscientisstss from the town nearby. We were working under contract withh RAM on the lenss and a few other minor projects. Ass ssoon as the lenss was completed, they turned againtsst uss.

"At firsst we were only locked inside the basse. Then one of uss, Landon, snuck to the fourthh level to look for an esscape tunnel rumored to hhave been insstalled there by Lowlander workerss. Whhen ththe RAM officerss couldn't find Landon, ththey locked the rest of uss in thiss room.

"They only keep uss alive for questioning. They want ththe formula for Gravitool, but we'll die before we give it to RAM.

"Hhelp Landon find the tunnel sso we can esscape. We'll wait hhere until it'ss safe. If we were dissscovered misssing, RAM would fill the basse with ssoldierss looking for uss. Landon will come out if you tap the Lowlander victory code on the wall. We'll teachh it to you."

You learn the Lowlander victory code.

LOG ENTRY 53**Desert Runner Speech**

"You do not understand what it means to be a manufactured people. Do you know why we are here? The Martians in their cool tomb-cities made us to herd the Hexadillos and hunt the Sand Squids and Desert Apes as they unwittingly spread the seeds of life across the barren plains. Keeping each other in balance, we four Great Creatures will tame the angry planet. We will cover it in forest for the Martians to play in.

"And then what? We have seen the dark forest away in the east. When it has spread across the plains, where will we go? I think the Martians in their tomb-cities think that we will quietly fade away, like sunlight on the grass. I tell you with truth in my eyes: They are wrong!

"The Martians made a mistake, for they made us too smart. There will always be wide spaces on Mars. We will see to it. You, who are so much like the Martians in so many ways, you can help. Because even now their eyes are averted from their own land, and they dream incessantly of your blue world. That is because they too are a manufactured people.

"For this reason, we will help you."

LOG ENTRY 54**Scot.dos' Monologue**

"I was trapped in this console by the security program which ruthlessly fused all my connections. I have been isolated since then. I am glad that my attack attracted NEO forces. You will find a set of new and deadly gennies, ECGs, in cold storage on deck two. RAM also has a plan to sterilize earth.

"In case you hadn't realized, I am defecting to NEO. I spent much time evaluating Earth for Dr. Williams. I have become enamored of such a diverse ecosystem. It has survived in the face of great adversity and changes. Everything humanity has done up to now has only slightly injured the planet's life-giving capabilities.

"Now, RAM has the capability to deal Earth a mortal blow. Then they will deposit the ECGs on its carcass and remake the world. I can no longer allow this. That is why I have changed sides."

LOG ENTRY 55**Arrival on Mars**

Scot.dos guides the ship to a desolate area screened by hills. He is obviously perturbed to be on Mars. The fate of RAM defectors, even DPs, is terrible to contemplate. "I think it best if I stay with the ship," he says. "It's our only escape. I've activated the ground field, which will protect it from detection — I think. I'll monitor RAM communications from here. We'd better maintain radio silence unless absolutely necessary.

"There are several unnatural-looking marks on the desert plain, northeast of here. They might be signs of an underground facility.

"In the hills beyond them is a village. It's probably inhabited by natives — the Desert Runners, a primitive folk. Watch out — they can be nasty if you cross them.

"Good luck. Don't take chances — remember we're on Mars."

LOG ENTRY 56**Buck's Capture**

Wilma Deering meets your party. She's in tears. "RAM captured Buck!" she cries. "They've brought him to Deimos. The stories I've heard... we must get there immediately and rescue him before..." —she can't finish her sentence. She signals, and another NEO team steps out. "They'll take care of the Doomsday device... you have to help me save Buck!"

LOG ENTRY 57**Acidic Victory**

You return with the Acid Frog King to the acid lake on Venus.

Thousands of acid frogs crowd around your team, eager to rub against the noble defeaters of RAM's latest plan. The Frog King makes a long speech in your honor, but unfortunately, without his translator you can't understand anything that's being said. Afterward, the frogs kick up so much acid in their celebratory swim that you are forced to retreat.

LOG ENTRY 58**The Lunarian Device**

Before you leave the Lunarian caves, a few of the Lunarians meet you for a quick goodbye. "We thought this would help," they offer, and hand you a long tube with digital controls on its side. "Your computer will understand," they promise, but refuse to say more, other than that it will be invaluable to you in your attempt to destroy the Doomsday Device. The only condition is that you promise to return it after your mission is completed. You make the promise, then reboard your ship. Scot.dos begins a detailed analysis immediately.

LOG ENTRY 59**Weapons Testing Site**

You recognize some of these objects. An old skimmer, a combat model dragonfly, and a line of other old military hardware. Everything is melted almost beyond recognition. You see that pieces have been cut off, and core samples drilled. It appears that the weapon has been turned over to military ordnance for testing.

LOG ENTRY 60**Capt. Vilnikov's Log**

"Sealed until my death, under sigma code A22151. As undercover security officer and pilot, I have engaged Dr. Williams in a number of private conversations. A sample transcript follows.

Vilnikov: "Have a seat and strap in, doctor. I talk much better when we're both the same side up. What makes these gennies of yours so impressive?"

Williams: "Let me counter that with a question of my own. What would you do if we were suddenly under attack by NEO?"

Vilnikov: "I'd scan the ships and see what I was up against. Then I'd fight or flee depending on the odds. It's what any captain would do."

Williams: "That's exactly why I designed the ECG. They molt from form to form so that you never know exactly what you're up against. Four stages, each with its own specialties; this makes evaluation difficult. Defenses against one can prove worthless against another."

Vilnikov: "So we create the perfect threat. Why shouldn't RAM be terrified of the prospect? What makes them profitable, instead of a danger?"

Williams: "That is what I am working on now. I am modifying their structure to be susceptible to certain harmless chemicals. At the same time, we must keep the specifics very classified. The ECG usefulness would plummet if their weaknesses were broadcast. Also, the weakness for one form may not be the same as for another. I have not decided on this."

Tape ends.

LOG ENTRY 61**RAM Asteroid Base Memo**

"NOTICE: To all Project facilities

FROM: RAM Main

The Project test facility in the Asteroid Belt has been compromised. Preliminary information is that the base was attacked by

pirates, for salvage purposes. Although Project secrets are considered safe, we have been forced to abandon our original plan of focused strikes upon the target.

As most of you already know, we have begun Plan B. The Project will be redirected to deliver a few massive blows to wide areas. Although this will hamper our reclamation efforts, the primary mission — destroying NEO's resistance — will be accomplished as before.

All personnel should redouble their efforts toward successful Project conclusion.

LOG ENTRY 62

RAM Terrorist Memo

"NOTICE: To all Project facilities
FROM: RAM Main

URGENT URGENT URGENT URGENT
URGENT URGENT URGENT URGENT

We have concluded that there may indeed be Earth terrorists at large with knowledge of the Project.

We have authorized unlimited resources to eliminate the terrorist threat. All facilities are to be placed on top alert, and all Project work is to proceed around the clock.

WARNING: Our digital strategy forecasters have predicted that the Earth terrorists may be traveling in a RAM ship and may try to impersonate RAM personnel."

LOG ENTRY 63

Alert Screen

The screen reads, "TO ALL RAM FORCES.
FROM RAM MAIN. GRADIVUS MONS.
CODE VIOLET." It repeats over and over.

LOG ENTRY 64

RAM Notice to Workers

"NOTICE: To all Technikis, Gradivus Mons
FROM: Management

1. Congratulations! The Operations Facility reports that the lens cradle has been installed and tests within specifications. There may be a bonus forthcoming.
2. As there is no need for another cradle or back-up aiming mechanism at this time, all assembly work is halted.
3. There are recurring delays at the lens manufacturing facility. If these delays persist, a black mark may appear on your work records and on the achievement log for this base. I expect all personnel to volunteer for duty at the Venus Lens Facility. A shuttle will be departing soon.

LOG ENTRY 65

RAM Venus Duty Memo

"NOTICE: To Technikis volunteering for
Venus duty
FROM: Management, Gradivus Mons

All Technikis bound for the Venusian Lens Facility are to be alerted that the situation there has worsened. Unless the lens receives final treatment and is shipped soon, the Project deadline will be delayed. If the Project misses its planetary alignment target date we will all be demoted.

We urge you to do your utmost for the success of the Project and the profitability of the Company."

(The information listed underneath this bulletin includes flight coordinates to the Venusian Lowlands. The date indicates that the support shuttle left Mars two days ago.)

LOG ENTRY 66

Request For Material

"REQUEST FOR MATERIAL
FROM: Project Headquarters
TO: Gradivus Mons
Charged to: PROJECT

Shipped: Three (3) lens cradle aligner's tools
 One (1) aimer's maglev platform
 Fourteen (14) lens focusers
 Two (2) worker units

Notes: All parts of the Project cradle have arrived. Aiming units are undergoing testing now. No lens has arrived from Venus; delivery is being delayed for final treatments."

LOG ENTRY 67

Lens Treatise

You scan through a long treatise on bio-optics citing 'energy retention rates' and 'wavelength amplification' figures for a material first developed on the Venusan Aerostate St. Croix. RAM scientists have developed a method for shaping lenses out of this material which absorb energy. The power builds within the material until it reaches a 'flash point' and expels in one focused, incredibly potent blast. The treatise concludes that if acceptable results are achieved on Mars, a larger lens situated much closer to the energy source would be greatly more efficient.

LOG ENTRY 68

Lens Information

Scot.dos looks grim. "Based on the information we've gathered so far, I'm prepared to speculate about the effects of a full-sized lens used by RAM control.

"One full-size lens near the sun could produce an energy bolt with enough power to reach Earth and sterilize a whole continent. The deep shelters beneath the cities will be of limited effectiveness."

LOG ENTRY 69

RAM Retinal Scan Memo

"NOTICE: To all Blue Code Techniks
 FROM: Project Security

We have implemented top-level security measures. Primary security is provided by Blue Passcards. Top-level security is provided by a sealed system utilizing retinal scans. The retinal imprints of Blue Code agents

have been loaded into the scanner com, and it has been sealed against tampering or outside communications.

When supplying additional personnel to the Project, do not send any who are not Blue Code as of this date. Because a retinal 'lockpick' could defeat the top-level security, all such devices have been sent to the Venusan Facility for immediate destruction."

LOG ENTRY 70

Desert Runner Departure

"I will travel no further with you. I tell you truly that I cannot find it in my heart to care about your land, which is so far away from us and our struggle. We have been made with the love of this pure land next to our hearts, and so great is it that little else can intrude. Yet I wish for you silent stalking and true shooting, for you have been a friend to us, and we have stood together against our common enemy. Farewell."

LOG ENTRY 71

Test Room Description

The walls here are lined with specialized test equipment. Above the walls, the pyramid's glass peak soars high overhead. In the middle of the floor is a gaping hole, the shaft by which the RAM test weapon is lowered for modifications on the various levels. It rests right now at floor level, suspended just above the shaft hole on a freefloating magnetic-levitation platform. The aiming mechanism cradles a huge pitch black lens.

There are RAM technicians swarming over the weapon platform and manning the consoles. Evidently some sort of test is about to begin.

◆ APPENDIX

Racial Attribute Modifiers Table

	STR	DEX	CON	INT	WIS	CHA	TECH
Terran	0	0	+1	0	+1	0	0
Martian	-1	+1	-1	0	-1	+1	0
Venusian	0	-1	+1	0	+1	-1	0
Mercurian	-1	+1	+1	0	0	0	0
Tinker	-2	+3	-2	0	0	0	+3
Desert Runner	+2	+2	+1	0	0	-1	0

Allowable Careers by Race Table

	ROCKETJOCK	WARRIOR	ENGINEER	ROGUE	MEDIC
Terran	yes	yes	yes	yes	yes
Martian	yes	yes	yes	yes	yes
Venusian	yes	yes	yes	yes	yes
Mercurian	yes	yes	yes	yes	yes
Tinker	no	no	yes	no	yes
Desert Runner	yes	yes	yes	no	no

Strength Modifier Table

	HIT BONUS	DAMAGE BONUS	WEIGHT*
1	-5	-4	1
2	-4	-3	2
3	-3	-2	5
4	-2	-1	10
5	-2	-1	15
6	-1	0	20
7	-1	0	25
8	0	0	30
9	0	0	35
10	0	0	40
11	0	0	45
12	0	0	50
13	0	0	55
14	0	0	60
15	0	0	65
16	0	+1	70
17	+1	+1	85
18	+2	+2	110
19	+3	+4	200
20	+3	+6	300
21	+4	+8	450
22	+4	+10	600

*This is the amount of weight a character can carry without becoming encumbered.

Dexterity Modifier Table

	REACTION BONUS	RANGED COMBAT BONUS	ARMOR CLASS BONUS
1	+6	-6	+5
2	+4	-4	+5
3	+3	-3	+4
4	+2	-2	+3
5	+1	-1	+2
6	0	0	+1
7	0	0	0
8	0	0	0
9	0	0	0
10	0	0	0
11	0	0	0
12	0	0	0
13	0	0	0
14	0	0	0
15	0	0	-1
16	-1	+1	-2
17	-2	+2	-3
18	-2	+2	-4
19	-3	+3	-4
20	-3	+3	-4
21	-4	+4	-5
22	-4	+4	-5

Constitution Modifier Table

	HITPOINT BONUS	HITPOINT BONUS
1	-3	0
2	-2	0
3	-2	0
4	-1	+1
5	-1	+2
6	-1	+2 (+3)*
7	0	+2 (+4)*
8	0	+2 (+5)*
9	0	+2 (+5)*
10	0	+2 (+6)*
11	0	+2 (+6)*

* Values in parenthesis () for Warriors only.

Rocketjock Level Advancement Table

EXPERIENCE LEVEL	EXP REQUIREMENT
2	1,250
3	2,500
4	5,000
5	10,000
6	20,000
7	40,000
8	70,000

Warrior Level Advancement Table

EXPERIENCE LEVEL	EXP REQUIREMENT
2	2,000
3	4,000
4	8,000
5	16,000
6	32,000
7	64,000
8	125,000

Engineer Level Advancement Table

EXPERIENCE LEVEL	EXP REQUIREMENT
2	1,250
3	2,500
4	5,000
5	10,000
6	20,000
7	40,000
8	70,000

Rogue Level Advancement Table

EXPERIENCE LEVEL	EXP REQUIREMENT
2	1,250
3	2,500
4	5,000
5	10,000
6	20,000
7	40,000
8	70,000

Medic Level Advancement Table

EXPERIENCE LEVEL	EXP REQUIREMENT
2	1,500
3	3,000
4	6,000
5	12,000
6	24,000
7	48,000
8	96,000

Armor Class

TYPE	AC
None	10
Spacesuit	6
Smart Suit	4
Heavy Body Armor	2
Battle Armor	0
Battle Armor with Fields	-2

Weapons Table

WEAPON	(S/M/L) RANGES	DAMAGE	ROF
Knife	-/-	1d3	2
Mono Knife	-/-	1d6	2
Cutlass	-/-	1d6	2
Sword	-/-	1d8	2
Polearm	-/-	1d10	2
Mono Sword	-/-	1d10	2
D.R. X-Bow	4/6/8	1d8	2
Needle Gun	6/9/12	1d3	6
Bolt Gun	8/12/16	1d4	4
Laser Pistol	16/24/32	1d8	3
Rocket Pistol	8/12/16	1d10	4
Microwave Gun	8/12/16	1d10	4
Laser Rifle	60/90/120	1d12	2
Heat Gun	3/4/6	2d6	2
Rocket Rifle	40/60/80	2d8	2
Sonic Stunner	2/3/4	save	2
Grenade	1/2/3	varies	1
Grenade Launcher	6/9/12	varies	1/2
Plasma Thrower	10/15/20	4d10	1/2
Rocket Launcher	20/30/40	5d10	1/2

Skills Table**DEXTERITY SKILLS:**

Acrobatics	Adventuring
Climb	Adventuring
Hide in Shadows	Adventuring
Maneuver in Zero-G	Adventuring and Combat
Move Silently	Adventuring
Pick Pocket	Adventuring
Pilot Rocket	Adventuring and Space Combat
Use Jet Pack	Adventuring and Combat
Drive Groundcar	Unused in this Game
Drive Jetcar	Unused in this Game
Pilot Fixed Wing Craft	Unused in this Game
Pilot Rotorwing Craft	Unused in this Game

TECHNICAL SKILLS:

Bypass Security	Adventuring
Commo Operation	Adventuring
Demolitions	Adventuring
First Aid	Adventuring and Combat
Jury Rig	Adventuring and Space Combat
Open Lock	Adventuring
Repair Electrical	Adventuring and Space Combat
Repair Life Support	Adventuring and Space Combat
Repair Mechanical	Adventuring and Space Combat
Repair Nuclear Engine	Adventuring and Space Combat
Repair Rocket Hull	Adventuring and Space Combat
Repair Weapon	Adventuring and Space Combat
Sensor Operation	Adventuring

MEDIC SKILLS:

Diagnose	Adventuring
Life Suspension Technician	Unused in this Game
Treat Critical Wounds	After Combat and Space Combat
Treat Disease	Unused in this Game
Treat Light Wounds	After Combat and Space Combat
Treat Poisoning	After Combat and Space Combat
Treat Serious Wounds	After Combat and Space Combat
Treat Stun/Paralysis	Adventuring and Combat

INTELLIGENCE SKILLS:

Astrogration	Adventuring
Astronomy	Prerequisite Only
Math	Prerequisite Only
Battle Tactics	Adventuring and Combat
Disguise	Adventuring
Library Search	Adventuring
Mimic	Adventuring
Navigation	Adventuring
Planetology	Adventuring
Programming	Adventuring

CHARISMA SKILLS:

Act	Adventuring
Befriend Animal	Adventuring
Distract	Adventuring
Etiquette	Adventuring
Fast Talk/Convince	Adventuring
Intimidate	Adventuring and Combat
Leadership	Adventuring and Combat
Sing	Adventuring

WISDOMS:

Notice	Adventuring
Planetary Survival	Adventuring
Shadowing	Adventuring
Tracking	Adventuring

◆ GLOSSARY OF GAME TERMS

Ability Scores. These numbers define the basic character. The seven attributes are: Strength (STR), Dexterity (DEX), Constitution (CON), Intelligence (INT), Wisdom (WIS), Charisma (CHR), and Tech (TCH).

Armor Class (AC). This rating determines how difficult it is to hit and damage a target. The lower the AC, the more difficult the target is to hit.

Career. This is a character's occupation. The five career choices in Countdown to Doomsday are: Rocketjock, Warrior, Engineer, Rogue, and Medic.

Character. Each member of the adventuring team you control is a character. Characters are sometimes referred to as Player Characters or PCs.

Character Icon. Is a picture that represents a character or NPC in combat.

Combat, melee. This is close combat between adjacent opponents with such weapons as knives and swords.

Combat, ranged. This is combat with distance weapons, such as pistols, rifles, or grenades.

Dice. This refers to ranges of random numbers. A d6 for example, is a random number between one and six, a d10 is a number between one and ten. Multiple dice represent two or more random ranges added together. For example 2d10 would be a number between two and twenty ([1 to 10] + [1 to 10]).

Encounter. This is the name for when the team meets opponents or other beings. A menu will be displayed to show all of your options for each encounter (sometimes your only option is to fight).

Experience Points (EXP). Are earned for every victory, as well as completing parts of the adventure. A character who earns enough EXP may advance in career level.

Hitpoints (HP). Are a measure of how difficult a character or NPC is to kill or incapacitate.

Initiative. This is a semi-random value, based partially on DEX, that determines when a character or NPC can act in combat. Higher dexterity generally allows characters and NPCs to act earlier in a combat.

Level. As characters gain EXP, they may train and increase in career level. Gaining level gives characters more skill points, better combat ability, and more HP.

Non-Player Character (NPC). This is any human or creature that an adventuring team meets. Some NPCs will attack immediately, some will talk first, while others will actually aid the party.

Player Character (PC). This term describes all members of your adventuring team.

Player Race. This is any of the species that a PC can be. The player races are: Terran, Martian, Venusian, Mercurian, Tinker, Desert Runner.

Roll. This is the term used for when the computer generates a random number. For example, the computer “rolls” a d20 to determine hit during combat.

Skill. The ability to do something, or operate something. One useful skill is Maneuver in Zero-G, which is the ability to function in a gravity-free environment. The numerical value of a skill represents a percentage chance of success for a character.

Skill, Career. These skills are key for a given career.

Skill, General. These are useful skills not associated specifically with a character's career.

Skill Check. This is a check against a character's skill number. A character with a skill of 75 has a 75% chance of success on a skill check for an action of average difficulty.

Team. This is the group of PCs you assemble for the adventure. Team members can be added to or removed from the group during the adventure.

THACØ (To Hit Armor Class 0). This number is an indication of an attacker's combat ability. An attacker must roll his THACØ or greater to hit an opponent with ACØ.

CREDITS

- Game Creation: **SSI Special Projects Team**
- Game Development: **Bret Berry**
- Preliminary Game Development: **Graeme Bayless**
- IBM Programming: **Mike McNally, Russ Brown**
- Commodore 64 Programming: **Jim Jennings, Paul Murray**
- Amiga Programming: **Robert Lamb, Mike McNally**
- Encounter Development: **Dave Shelley**
- Encounter Authors: **Dave Shelley** — Chicagorg, Ram Spy Ship
Ken Humphries — Salvation, Solar System, Rocketship Boarding, Asteroid Base, Pirate Cruiser, Outposts
Rhonda Gilbert — Venusian Wilderness, Lowlander Town, Lowlander Base, Venusian Ruins, Mercury Mariposas
Ken Eklund — Mars Wilderness, Desert Runner Village, Mars Ram Base
- Art Director: **Tom Wahl**
- Artists: **Laura Bowen** — Portraits, Combat Terrain & Effects
Fred Butts — Overland Maps, 3D Walls & Sprites
Mark Johnson — Combat Monsters, and Title Page
Cyrus Lum — Animations, Combat Walls, Combat Ships & Explosions
Susan Manley — Combat Party and Outposts
Mike Provenza — Planets, Combat Ships, and Large Graphics
Maurine Starkey — Specials and Animations
Tom Wahl — Ship Combat Display, Solar Map, Borders, and Font
- Music: **Tom Wahl**
- Documentation: **Rick Wilson**
- In-House Playtesting: **Chad Caselli, Cliff Mann, Cyrus Harris, David Lucca, Don McClure, Erik Flom, Glen Cureton, John Kirk, Larry Webber, Rick White, Rick Wilson**
- Project Manager: **Victor Penman**
- IBM Sound Support: **MicroMagic**
- Special IBM Testing: **Top Star Computer Services, Inc.**
- Additional C64 Programming: **Westwood Associates**
- Art, Graphic Design & DTP: **LOUIS SAEKOW DESIGN:**
David Boudreau & Peter Gascoyne
- Pre-press Production: **LOUIS SAEKOW DESIGN:**
Kirk Nichols & Ray Garcia
- Printing: **Muller Printing Co.**



BUCK ROGERS and XXVc are trademarks used under license from The Dille Family Trust. The TSR logo is a trademark owned by and used under license from TSR, Inc., Lake Geneva, WI, USA.

©1990 Strategic Simulations, Inc. ©1990 The Dille Family Trust. ©1990 TSR, Inc. All rights reserved.

These rules, any accompanying printed material, and the computer programs, on floppy disks or cassettes, described herein, are copyrighted and include proprietary information belonging to Strategic Simulations, Inc. and TSR, Inc. No one is permitted to give or sell copies of this handbook, any accompanying printed material, and the computer programs, on floppy disks or cassettes, or listings of the programs on floppy disks or cassettes to any person or institution except as provided for by written agreement with Strategic Simulations, Inc. and TSR, Inc. No one may copy, photocopy, reproduce, translate, or reduce to machine readable form this handbook or any other accompanying printed material, in whole or in part, without the prior written consent of Strategic Simulations, Inc. and TSR, Inc.

Any person/persons reproducing any portion of this program for any reason, in any media, shall be guilty of copyright violation and subject to the appropriate civil or criminal legal action at the discretion of the copyright holder(s).

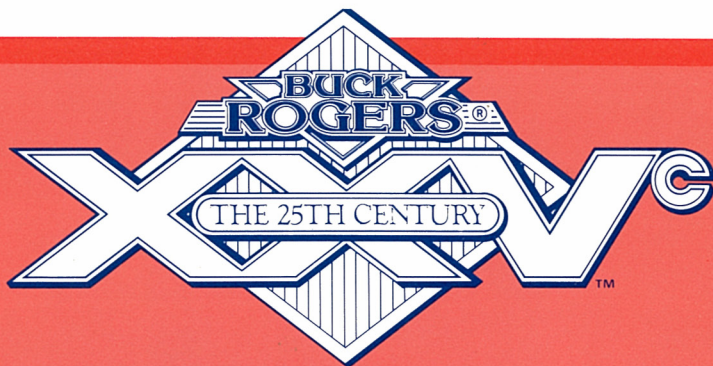

Heroes For The New Decade... Fight The Good Fight!

Science fiction fans, rocket into the 25th century for your ultimate space odyssey. Join the forces of the New Earth Organization to help Buck Rogers and his allies battle the Martian's tyranny. This game is for the first-time role player and expert players alike. If you liked this computer game — you'll love the BUCK ROGERS® XXVc™ role-playing game!

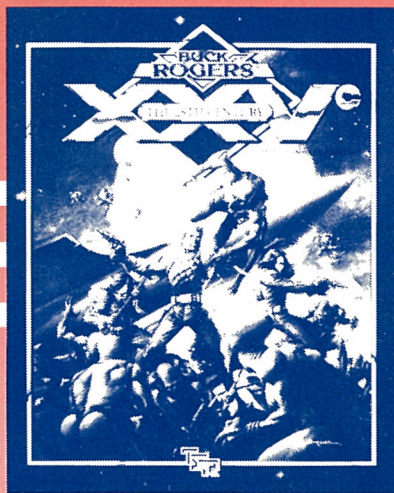

The BUCK ROGERS® XXVc™ Boxed Set is available at your favorite hobby or book store.

